

 **PRAMET**



VRTÁNÍ / DRILLING

ZNAČENÍ, POPIS A PŘEHLED VRTÁKŮ MARKING, DESCRIPTION AND OVERVIEW OF DRILLS

Strana/Page: 2

MONOLITNÍ VRTÁKY SOLID DRILLS

Strana/Page: 8

DESTIČKOVÉ VRTÁKY INDEXABLE DRILLS

Strana/Page: 28

VYMĚNITELNÉ BŘITOVÉ DESTIČKY (VBD) INDEXABLE CUTTING INSERTS

Strana/Page: 42

NASTAVITELNÉ POUZDRO ADJUSTABLE SLEEVE

Strana/Page: 46

ŘEZNÉ PODMÍNKY CUTTING CONDITIONS

Strana/Page: 48

TECHNICKÁ ČÁST TECHNICAL PART

Strana/Page: 52

OBSAH
CONTENTMONOLITNÍ VRTÁKY
SOLID DRILLSDESTIČKOVÉ VRTÁKY
INDEXABLE DRILLSVYMĚNITELNÉ DESTIČKY
INDEXABLE INSERTSNASTAVITELNÉ POUZDRO
ADJUSTABLE SLEEVEŘEZNÉ PODMÍNKY
CUTTING CONDITIONSTECHNICKÁ ČÁST
TECHNICAL PART

TECHNICKÁ ČÁST TECHNICAL PART	ŘEZNÉ PODMÍNKY CUTTING CONDITIONS	NASTAVITELNÉ POUZDRO ADJUSTABLE SLEEVE	VYMĚNITELNÉ DESTIČKY INDEXABLE INSERTS	DESTIČKOVÉ VRTÁKY INDEXABLE DRILLS	MONOLITNÍ VRTÁKY SOLID DRILLS	OBSAH CONTENT



1	2	3	4	5	6	8	9
3	03	D	A	- 9,0	- 35	- A	10

Monolitní vrták / Solid drill

1	2	3	4	5	6	8	9
3	05	D	A	- 6,0	- 35	- A	06

Srážeč hran / Chamfer drill

1	2	3	4	5	6A	7	8	9
3	01	C	S	- 6,0	- 50	- P60	A	06

Stupňovitý vrták / Step drill

1	2	3	4	5	6	7A	8	9
3	03	T	A	- 6,8	- 21,0	- C45	A	10

Destičkový vrták / Indexable drill *

1	2	3	4	5	6	8	9
8	04	D		- 20	- 80	- S	25











*Značení platí pro typy vyrobené od roku 2011 / Marking is valid for types produced from 2011









1	2	3	4	5	6
Druh nástroje Tool type	Přibližná délka Approximate length	Provedení Variant	Chlazení Cooling	Řezný průměr Cutting diameter	Max. hloubka vrtání Max. drilling depth
3 Monolitní vrták Solid drill	01 1 × D 03 3 × D	C Odjehlovací vrták Chamfer drill D Vrták Drill	A Vnitřní chlazení Internal cooling S Bez chlazení Without cooling	3,0 D 3 mm 6,8 D 6,8 mm 12,0 D 12 mm 16,5 D 16,5 mm 20,0 D 20 mm	35 35 mm 68 68 mm 140 140 mm
8 Destičkový vrták Indexable drill	05 5 × D 08 8 × D	F 4 fazetkový vrták 4 land margins drill T Stupňovitý vrták Step drill			



















6A	7
Celková délka Total length	Úhel špičky Point angle
50 50 mm 70 70 mm 100 100 mm	- 140° P60 60° P90 90° P120 120°

7A	8
Úhel sražení Chamfer angle	Typ stopky Type of shank
C30 30° C45 45° C60 60°	A Válcová Cylindrical B Weldon E Whistle Notch S ISO 9766

9
Průměr stopky Shank diameter
06 D 6 mm 08 D 8 mm 10 D 10 mm 12 D 12 mm 14 D 14 mm 16 D 16 mm 18 D 18 mm 20 D 20 mm































Symbol	Popis	Description
	Vrtání slepé díry	Blind hole drilling
	Vrtání průchozí díry	Through hole drilling
	Nastavitelný průměr vrtáku	Adjustable drill diameter
	Vrtání do předvrtaného středícího důlku	Drilling into center drilled hole
	Vrtání napříč stávajících otvorů	Drilling across an existing hole
	Vyvrtování	Boring
	Přerušovaný řez nebo ponorné vrtání	Interrupted cut or plunging
	Vrtání do zakřiveného povrchu	Drilling on curved surface
	Vrtání do zkoseného povrchu	Drilling on slanted surface
	Vrtání přes svar	Welded joint drilling
	Vrtání naskládaných materiálů	Drilling of stacked materials

Symbol	Popis	Description
	Obráběný materiál podle ISO 513	Cutting material according to ISO 513
	Provedení stopky - válcová	Type of shank - cylindrical
	Provedení stopky - univerzální	Type of shank - universal
	Přibližná pracovní délka	Aproximate working length
	Vnitřní chlazení	Internal cooling
	Vnější chlazení	External cooling
	Typ nástroje - vrták	Type of tool - drill
	Typ nástroje - srážecí hran	Type of tool - chamfer drill
	Typ nástroje - stupňovitý vrták	Type of tool - step drill
	Typ nástroje - vrták se 4 fazetkami	Type of tool - 4 land margins drill

Pracovní délka Working length	 3D	 3D	 5D	 8D	 3D	 1D
Foto Picture						
Chlazení Cooling						
Strana Page	8–11	12–15	16–19	20–23	24	25–27
Typ vrtáku Drill type	303DS	303DA	305DA	308FA	303TA	301CS
Tolerance vrtáku Drill tolerance	m7	m7	m7	m7	m7	h6
Stupeň přesnosti díry * Hole tolerance *	IT 8–9	IT 8–9	IT 8–9	IT 8–9	IT 8–9	—
Drsnost povrchu * Surface finish *	Ra 1–2 µm	Ra 1–2 µm	Ra 1–2 µm	Ra 1–2 µm	Ra 1–2 µm	—
Rozsah průměrů Diameter range	3,0–20,0	3,0–20,0	3,0–20,0	3,0–16,0	3,3–14,5	6,0–16,0
P_I	■	■	■	■	■	■
P_{II}	■	■	■	■	■	■
P_{III}	■	■	■	■	■	■
P_{IV}	■	■	■	■	■	■
M		□	□	□	□	
K	■	■	■	■	■	■
N						
S						
H						

* Tolerance vrtaného otvoru a jakost povrchu jsou značně závislé na podmínkách obrábění
* The tolerance of drilled hole and surface finish are heavily dependent on machining conditions

■ - hlavní oblast použití / main application □ - omezené použití / conditional application

Pracovní délka Working length						
Foto Picture						
Chlazení Cooling						
Strana Page	28–29	30–33	34–35	36–37	38–39	40–41
Typ vrtáku Drill type	802D	803D	804D	805D	7720	7720.1
Tolerance vrtáku Drill tolerance	± 0,05	± 0,05	± 0,05	± 0,05	± 0,1	± 0,1
Stupeň přesnosti díry * Hole tolerance *	0/+0,2	0/+0,3	0/+0,4	0/+0,5	-0,1/+0,3	-0,1/+0,4
Drsnost povrchu * Surface finish *	Ra 2–6 µm	Ra 2–6 µm	Ra 2–6 µm	Ra 2–6 µm	Ra 3–12,5 µm	Ra 3–12,5 µm
Rozsah průměrů Diameter range	15,0–40,0	15,0–58,0	17,0–40,0	19,0–31,0	41,0–58,0	41,0–58,0
Středová destička Centre insert	 XPET	 XPET	 XPET	 XPET	 WCMT	 WCMT
Obvodová destička Peripheral insert	 SCET	 SCET	 SCET	 SCET	 WCMT	 WCMT
<p>* Tolerance vrtného otvoru a jakost povrchu jsou značně závislé na podmínkách obrábění * The tolerance of drilled hole and surface finish are heavily dependent on machining conditions</p>						

TYP/TYPE 303DS

MONOLITNÍ VRTÁKY SOLID DRILLS



Viz strana 48 / See page 48

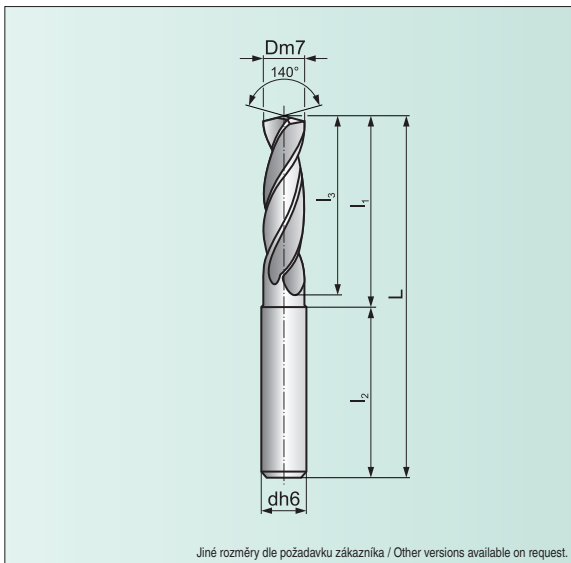

Jiné rozměry dle požadavku zákazníka / Other versions available on request.



● Doporučené použití / Recommended application

○ Možné použití (více str.52) / Possible applications (see more on pg. 52)

○ Nedoporučuje se / Not recommended

Dm7		Označení vrtáku Marking of drill	Sortiment/Assortment	Rozměry / Dimensions					-
				L	l ₁	l ₂	l ₃	dh6	
3,0	13	303DS-3,0-13-A06	●	62	26	36	20	6	-
3,1	13	303DS-3,1-13-A06	●	62	26	36	20	6	-
3,2	13	303DS-3,2-13-A06	●	62	26	36	20	6	-
3,3	13	303DS-3,3-13-A06	●	62	26	36	20	6	-
3,4	13	303DS-3,4-13-A06	●	62	26	36	20	6	-
3,5	13	303DS-3,5-13-A06	●	62	26	36	20	6	-
3,6	13	303DS-3,6-13-A06	●	62	26	36	20	6	-
3,7	13	303DS-3,7-13-A06	●	62	26	36	20	6	-
3,8	16	303DS-3,8-16-A06	●	66	30	36	24	6	-
3,9	16	303DS-3,9-16-A06	●	66	30	36	24	6	-
4,0	16	303DS-4,0-16-A06	●	66	30	36	24	6	-
4,1	16	303DS-4,1-16-A06	●	66	30	36	24	6	-
4,2	16	303DS-4,2-16-A06	●	66	30	36	24	6	-
4,3	16	303DS-4,3-16-A06	●	66	30	36	24	6	-
4,4	16	303DS-4,4-16-A06	●	66	30	36	24	6	-
4,5	16	303DS-4,5-16-A06	●	66	30	36	24	6	-
4,6	16	303DS-4,6-16-A06	●	66	30	36	24	6	-
4,7	16	303DS-4,7-16-A06	○	66	30	36	24	6	-
4,8	20	303DS-4,8-20-A06	●	66	30	36	28	6	-
4,9	20	303DS-4,9-20-A06	●	66	30	36	28	6	-
5,0	20	303DS-5,0-20-A06	●	66	30	36	28	6	-

● Skladovaný / Stock Assort.

○ Neskladovaný / Non-stock assort.

Všechny rozměry v [mm] / All dimensions [mm]

Dm7		Označení vrtáku Marking of drill	Sortiment/ Assortment	Rozměry / Dimensions					-
				L	l ₁	l ₂	l ₃	dh6	
5,1	20	303DS-5,1-20-A06	●	66	30	36	28	6	-
5,2	20	303DS-5,2-20-A06	●	66	30	36	28	6	-
5,3	20	303DS-5,3-20-A06	○	66	30	36	28	6	-
5,4	20	303DS-5,4-20-A06	○	66	30	36	28	6	-
5,5	20	303DS-5,5-20-A06	●	66	30	36	28	6	-
5,6	20	303DS-5,6-20-A06	○	66	30	36	28	6	-
5,7	20	303DS-5,7-20-A06	○	66	30	36	28	6	-
5,8	20	303DS-5,8-20-A06	●	66	30	36	28	6	-
5,9	20	303DS-5,9-20-A06	●	66	30	36	28	6	-
6,0	20	303DS-6,0-20-A06	●	66	30	36	28	6	-
6,1	24	303DS-6,1-24-A08	○	79	43	36	34	8	-
6,2	24	303DS-6,2-24-A08	○	79	43	36	34	8	-
6,3	24	303DS-6,3-24-A08	○	79	43	36	34	8	-
6,4	24	303DS-6,4-24-A08	○	79	43	36	34	8	-
6,5	24	303DS-6,5-24-A08	●	79	43	36	34	8	-
6,6	24	303DS-6,6-24-A08	●	79	43	36	34	8	-
6,7	24	303DS-6,7-24-A08	○	79	43	36	34	8	-
6,8	24	303DS-6,8-24-A08	●	79	43	36	34	8	-
6,9	24	303DS-6,9-24-A08	●	79	43	36	34	8	-
7,0	24	303DS-7,0-24-A08	●	79	43	36	34	8	-
7,1	29	303DS-7,1-29-A08	○	79	43	36	41	8	-
7,2	29	303DS-7,2-29-A08	○	79	43	36	41	8	-
7,3	29	303DS-7,3-29-A08	○	79	43	36	41	8	-
7,4	29	303DS-7,4-29-A08	○	79	43	36	41	8	-
7,5	29	303DS-7,5-29-A08	●	79	43	36	41	8	-
7,6	29	303DS-7,6-29-A08	○	79	43	36	41	8	-
7,7	29	303DS-7,7-29-A08	○	79	43	36	41	8	-
7,8	29	303DS-7,8-29-A08	●	79	43	36	41	8	-
7,9	29	303DS-7,9-29-A08	●	79	43	36	41	8	-
8,0	29	303DS-8,0-29-A08	●	79	43	36	41	8	-
8,1	35	303DS-8,1-35-A10	○	89	49	40	47	10	-
8,2	35	303DS-8,2-35-A10	●	89	49	40	47	10	-
8,3	35	303DS-8,3-35-A10	○	89	49	40	47	10	-
8,4	35	303DS-8,4-35-A10	○	89	49	40	47	10	-
8,5	35	303DS-8,5-35-A10	●	89	49	40	47	10	-
8,6	35	303DS-8,6-35-A10	○	89	49	40	47	10	-
8,7	35	303DS-8,7-35-A10	●	89	49	40	47	10	-
8,8	35	303DS-8,8-35-A10	●	89	49	40	47	10	-
8,9	35	303DS-8,9-35-A10	○	89	49	40	47	10	-
9,0	35	303DS-9,0-35-A10	●	89	49	40	47	10	-
9,1	35	303DS-9,1-35-A10	○	89	49	40	47	10	-
9,2	35	303DS-9,2-35-A10	○	89	49	40	47	10	-
9,3	35	303DS-9,3-35-A10	○	89	49	40	47	10	-
9,4	35	303DS-9,4-35-A10	○	89	49	40	47	10	-
9,5	35	303DS-9,5-35-A10	●	89	49	40	47	10	-

pokračování na další straně / continues on next page...

● Skladovaný / Stock Assort. ○ Neskladovaný / Non-stock assort.

Všechny rozměry v [mm] / All dimensions [mm]

TYP/TYPE 303DS

MONOLITNÍ VRTÁKY SOLID DRILLS



Viz strana 48 / See page 48

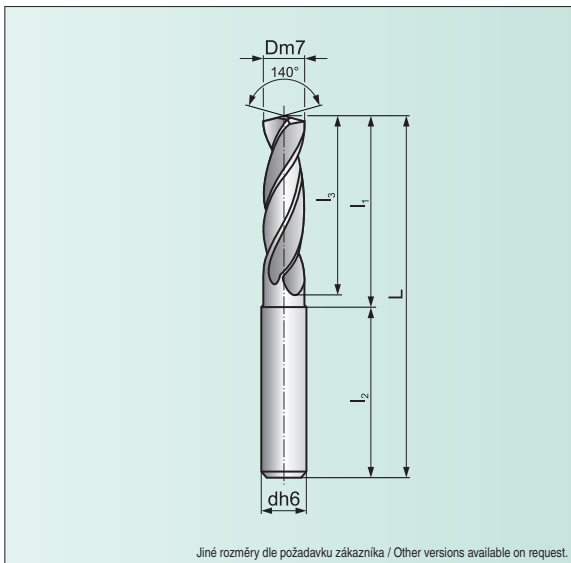

Jiné rozměry dle požadavku zákazníka / Other versions available on request.



● Doporučené použití / Recommended application

● Možné použití (více str.52) / Possible applications (see more on pg. 52)

○ Nedoporučuje se / Not recommended

Dm7	h	Označení vrtáku Marking of drill	Sortiment / Assortment	Rozměry / Dimensions					-
				L	l ₁	l ₂	l ₃	dh6	
...pokračování z předchozí strany / continues from previous page									
9,6	35	303DS-9,6-35-A10	○	89	49	40	47	10	-
9,7	35	303DS-9,7-35-A10	○	89	49	40	47	10	-
9,8	35	303DS-9,8-35-A10	●	89	49	40	47	10	-
9,9	35	303DS-9,9-35-A10	●	89	49	40	47	10	-
10,0	35	303DS-10,0-35-A10	●	89	49	40	47	10	-
10,1	40	303DS-10,1-40-A12	○	102	57	45	55	12	-
10,2	40	303DS-10,2-40-A12	●	102	57	45	55	12	-
10,3	40	303DS-10,3-40-A12	○	102	57	45	55	12	-
10,4	40	303DS-10,4-40-A12	●	102	57	45	55	12	-
10,5	40	303DS-10,5-40-A12	●	102	57	45	55	12	-
10,6	40	303DS-10,6-40-A12	○	102	57	45	55	12	-
10,7	40	303DS-10,7-40-A12	○	102	57	45	55	12	-
10,8	40	303DS-10,8-40-A12	●	102	57	45	55	12	-
10,9	40	303DS-10,9-40-A12	○	102	57	45	55	12	-
11,0	40	303DS-11,0-40-A12	●	102	57	45	55	12	-
11,1	40	303DS-11,1-40-A12	○	102	57	45	55	12	-
11,2	40	303DS-11,2-40-A12	○	102	57	45	55	12	-
11,3	40	303DS-11,3-40-A12	○	102	57	45	55	12	-
11,4	40	303DS-11,4-40-A12	○	102	57	45	55	12	-
11,5	40	303DS-11,5-40-A12	●	102	57	45	55	12	-

● Skladovaný / Stock Assort.

○ Neskladovaný / Non-stock assort.

Všechny rozměry v [mm] / All dimensions [mm]

Dm7		Označení vrtáku Marking of drill	Sortiment/ Assortment	Rozměry / Dimensions					-
				L	l ₁	l ₂	l ₃	dh6	
11,6	40	303DS-11,6-40-A12	○	102	57	45	55	12	-
11,7	40	303DS-11,7-40-A12	○	102	57	45	55	12	-
11,8	40	303DS-11,8-40-A12	●	102	57	45	55	12	-
11,9	40	303DS-11,9-40-A12	○	102	57	45	55	12	-
12,0	40	303DS-12,0-40-A12	●	102	57	45	55	12	-
12,2	43	303DS-12,2-43-A14	○	107	62	45	60	14	-
12,5	43	303DS-12,5-43-A14	●	107	62	45	60	14	-
12,8	43	303DS-12,8-43-A14	●	107	62	45	60	14	-
13,0	43	303DS-13,0-43-A14	●	107	62	45	60	14	-
13,3	43	303DS-13,3-43-A14	○	107	62	45	60	14	-
13,5	43	303DS-13,5-43-A14	●	107	62	45	60	14	-
13,8	43	303DS-13,8-43-A14	●	107	62	45	60	14	-
14,0	43	303DS-14,0-43-A14	●	107	62	45	60	14	-
14,5	45	303DS-14,5-45-A16	●	115	67	48	65	16	-
15,0	45	303DS-15,0-45-A16	●	115	67	48	65	16	-
15,3	45	303DS-15,3-45-A16	○	115	67	48	65	16	-
15,5	45	303DS-15,5-45-A16	○	115	67	48	65	16	-
15,8	45	303DS-15,8-45-A16	○	115	67	48	65	16	-
16,0	45	303DS-16,0-45-A16	○	115	67	48	65	16	-
16,5	51	303DS-16,5-51-A18	○	123	75	48	73	18	-
17,0	51	303DS-17,0-51-A18	○	123	75	48	73	18	-
17,5	51	303DS-17,5-51-A18	○	123	75	48	73	18	-
18,0	51	303DS-18,0-51-A18	○	123	75	48	73	18	-
18,5	55	303DS-18,5-55-A20	○	131	81	50	79	20	-
19,0	55	303DS-19,0-55-A20	○	131	81	50	79	20	-
19,5	55	303DS-19,5-55-A20	○	131	81	50	79	20	-
20,0	55	303DS-20,0-55-A20	○	131	81	50	79	20	-

● Skladovaný / Stock Assort.

○ Neskladovaný / Non-stock assort.

Všechny rozměry v [mm] / All dimensions [mm]

TYP/TYPE 303DA

MONOLITNÍ VRTÁKY SOLID DRILLS



Viz strana 48 / See page 48

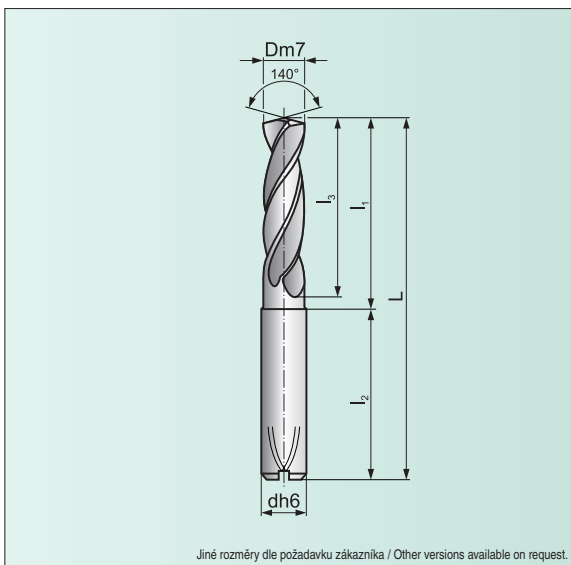

Jiné rozměry dle požadavku zákazníka / Other versions available on request.



● Doporučené použití / Recommended application

○ Možné použití (více str.52) / Possible applications (see more on pg. 52)

○ Nedoporučuje se / Not recommended

Dm7	 h	Označení vrtáku Marking of drill	Sortiment/Assortment	Rozměry / Dimensions					-
				L	l ₁	l ₂	l ₃	dh6	
3,0	14	303DA-3,0-14-A06	●	62	26	36	20	6	-
3,1	14	303DA-3,1-14-A06	○	62	26	36	20	6	-
3,2	14	303DA-3,2-14-A06	○	62	26	36	20	6	-
3,3	14	303DA-3,3-14-A06	○	62	26	36	20	6	-
3,4	14	303DA-3,4-14-A06	●	62	26	36	20	6	-
3,5	14	303DA-3,5-14-A06	●	62	26	36	20	6	-
3,6	14	303DA-3,6-16-A06	○	62	26	36	20	6	-
3,7	14	303DA-3,7-16-A06	○	62	26	36	20	6	-
3,8	17	303DA-3,8-16-A06	●	66	30	36	24	6	-
3,9	17	303DA-3,9-16-A06	○	66	30	36	24	6	-
4,0	17	303DA-4,0-17-A06	●	66	30	36	24	6	-
4,1	17	303DA-4,1-17-A06	○	66	30	36	24	6	-
4,2	17	303DA-4,2-17-A06	●	66	30	36	24	6	-
4,3	17	303DA-4,3-18-A06	●	66	30	36	24	6	-
4,4	17	303DA-4,4-18-A06	○	66	30	36	24	6	-
4,5	17	303DA-4,5-18-A06	●	66	30	36	24	6	-
4,6	17	303DA-4,6-18-A06	○	66	30	36	24	6	-
4,7	17	303DA-4,7-19-A06	○	66	30	36	24	6	-
4,8	20	303DA-4,8-20-A06	●	66	30	36	28	6	-
4,9	20	303DA-4,9-20-A06	●	66	30	36	28	6	-
5,0	20	303DA-5,0-20-A06	●	66	30	36	28	6	-

● Skladovaný / Stock Assort.

○ Neskladovaný / Non-stock assort.

Všechny rozměry v [mm] / All dimensions [mm]

Dm7		Označení vrtáku Marking of drill	Sortiment/ Assortment	Rozměry / Dimensions					-
				L	l ₁	l ₂	l ₃	dh6	
5,1	20	303DA-5,1-20-A06	●	66	30	36	28	6	-
5,2	20	303DA-5,2-20-A06	●	66	30	36	28	6	-
5,3	20	303DA-5,3-20-A06	○	66	30	36	28	6	-
5,4	20	303DA-5,4-20-A06	○	66	30	36	28	6	-
5,5	20	303DA-5,5-20-A06	●	66	30	36	28	6	-
5,6	20	303DA-5,6-20-A06	○	66	30	36	28	6	-
5,7	20	303DA-5,7-20-A06	○	66	30	36	28	6	-
5,8	20	303DA-5,8-20-A06	●	66	30	36	28	6	-
5,9	20	303DA-5,9-20-A06	●	66	30	36	28	6	-
6,0	20	303DA-6,0-20-A06	●	66	30	36	28	6	-
6,1	24	303DA-6,1-24-A08	○	79	43	36	34	8	-
6,2	24	303DA-6,2-24-A08	○	79	43	36	34	8	-
6,3	24	303DA-6,3-24-A08	○	79	43	36	34	8	-
6,4	24	303DA-6,4-24-A08	○	79	43	36	34	8	-
6,5	24	303DA-6,5-24-A08	●	79	43	36	34	8	-
6,6	24	303DA-6,6-24-A08	●	79	43	36	34	8	-
6,7	24	303DA-6,7-24-A08	○	79	43	36	34	8	-
6,8	24	303DA-6,8-24-A08	●	79	43	36	34	8	-
6,9	24	303DA-6,9-24-A08	●	79	43	36	34	8	-
7,0	24	303DA-7,0-24-A08	●	79	43	36	34	8	-
7,1	29	303DA-7,1-29-A08	○	79	43	36	41	8	-
7,2	29	303DA-7,2-29-A08	○	79	43	36	41	8	-
7,3	29	303DA-7,3-29-A08	○	79	43	36	41	8	-
7,4	29	303DA-7,4-29-A08	○	79	43	36	41	8	-
7,5	29	303DA-7,5-29-A08	●	79	43	36	41	8	-
7,6	29	303DA-7,6-29-A08	○	79	43	36	41	8	-
7,7	29	303DA-7,7-29-A08	○	79	43	36	41	8	-
7,8	29	303DA-7,8-29-A08	●	79	43	36	41	8	-
7,9	29	303DA-7,9-29-A08	●	79	43	36	41	8	-
8,0	29	303DA-8,0-29-A08	●	79	43	36	41	8	-
8,1	35	303DA-8,1-35-A10	●	89	49	40	47	10	-
8,2	35	303DA-8,2-35-A10	●	89	49	40	47	10	-
8,3	35	303DA-8,3-35-A10	○	89	49	40	47	10	-
8,4	35	303DA-8,4-35-A10	○	89	49	40	47	10	-
8,5	35	303DA-8,5-35-A10	●	89	49	40	47	10	-
8,6	35	303DA-8,6-35-A10	●	89	49	40	47	10	-
8,7	35	303DA-8,7-35-A10	●	89	49	40	47	10	-
8,8	35	303DA-8,8-35-A10	●	89	49	40	47	10	-
8,9	35	303DA-8,9-35-A10	●	89	49	40	47	10	-
9,0	35	303DA-9,0-35-A10	●	89	49	40	47	10	-
9,1	35	303DA-9,1-35-A10	○	89	49	40	47	10	-
9,2	35	303DA-9,2-35-A10	○	89	49	40	47	10	-
9,3	35	303DA-9,3-35-A10	○	89	49	40	47	10	-
9,4	35	303DA-9,4-35-A10	○	89	49	40	47	10	-
9,5	35	303DA-9,5-35-A10	●	89	49	40	47	10	-

pokračování na další straně / continues on next page...

● Skladovaný / Stock Assort. ○ Neskladovaný / Non-stock assort.

Všechny rozměry v [mm] / All dimensions [mm]

TYP/TYPE 303DA

MONOLITNÍ VRTÁKY SOLID DRILLS



Viz strana 48 / See page 48

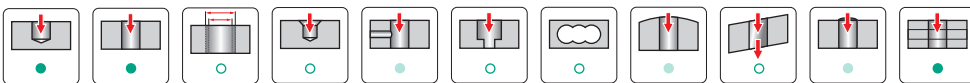
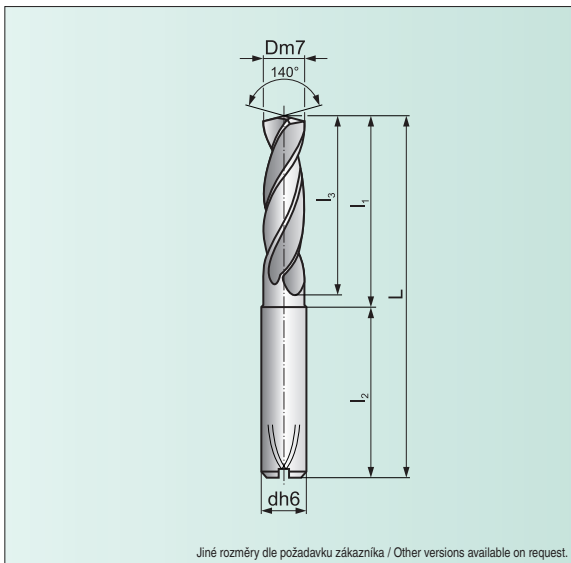

● Doporučené použití / Recommended application ● Možné použití (více str.52) / Possible applications (see more on pg. 52) ○ Nedoporučuje se / Not recommended

Dm7	h	Označení vrtáku Marking of drill	Sortiment/Assortment	Rozměry / Dimensions					-
				L	l_1	l_2	l_3	dh6	
...pokračování z předchozí strany / continues from previous page									
9,6	35	303DA-9,6-35-A10	○	89	49	40	47	10	-
9,7	35	303DA-9,7-35-A10	○	89	49	40	47	10	-
9,8	35	303DA-9,8-35-A10	●	89	49	40	47	10	-
9,9	35	303DA-9,9-35-A10	●	89	49	40	47	10	-
10,0	35	303DA-10,0-35-A10	●	89	49	40	47	10	-
10,2	40	303DA-10,2-40-A12	●	102	57	45	55	12	-
10,5	40	303DA-10,5-40-A12	●	102	57	45	55	12	-
10,8	40	303DA-10,8-40-A12	●	102	57	45	55	12	-
11,0	40	303DA-11,0-40-A12	●	102	57	45	55	12	-
11,2	40	303DA-11,2-40-A12	○	102	57	45	55	12	-
11,3	40	303DA-11,3-40-A12	○	102	57	45	55	12	-
11,5	40	303DA-11,5-40-A12	●	102	57	45	55	12	-
11,8	40	303DA-11,8-40-A12	●	102	57	45	55	12	-
12,0	40	303DA-12,0-40-A12	●	102	57	45	55	12	-
12,2	43	303DA-12,2-43-A14	○	107	62	45	60	14	-
12,5	43	303DA-12,5-43-A14	●	107	62	45	60	14	-
12,8	43	303DA-12,8-43-A14	●	107	62	45	60	14	-
13,0	43	303DA-13,0-43-A14	●	107	62	45	60	14	-
13,3	43	303DA-13,3-43-A14	○	107	62	45	60	14	-
13,5	43	303DA-13,5-43-A14	●	107	62	45	60	14	-

● Skladovaný / Stock Assort. ○ Neskladovaný / Non-stock assort.

Všechny rozměry v [mm] / All dimensions [mm]

Dm7		Označení vrtáku Marking of drill	Sortiment / Assortment	Rozměry / Dimensions					-
				L	l ₁	l ₂	l ₃	dh6	
13,8	43	303DA-13,8-43-A14	●	107	62	45	60	14	-
14,0	43	303DA-14,0-43-A14	●	107	62	45	60	14	-
14,5	45	303DA-14,5-45-A16	●	115	67	48	65	16	-
15,0	45	303DA-15,0-45-A16	●	115	67	48	65	16	-
15,3	45	303DA-15,3-45-A16	○	115	67	48	65	16	-
15,5	45	303DA-15,5-45-A16	○	115	67	48	65	16	-
15,8	45	303DA-15,8-45-A16	○	115	67	48	65	16	-
16,0	45	303DA-16,0-45-A16	○	115	67	48	65	16	-
16,5	51	303DA-16,5-51-A18	○	123	75	48	73	18	-
17,0	51	303DA-17,0-51-A18	○	123	75	48	73	18	-
17,5	51	303DA-17,5-51-A18	○	123	75	48	73	18	-
18,0	51	303DA-18,0-51-A18	○	123	75	48	73	18	-
18,5	55	303DA-18,5-55-A20	○	131	81	50	79	20	-
19,0	55	303DA-19,0-55-A20	○	131	81	50	79	20	-
19,5	55	303DA-19,5-55-A20	○	131	81	50	79	20	-
20,0	55	303DA-20,0-55-A20	○	131	81	50	79	20	-

● Skladovaný / Stock Assort.

○ Neskladovaný / Non-stock assort.

Všechny rozměry v [mm] / All dimensions [mm]

TYP/TYPE 305DA

MONOLITNÍ VRTÁKY SOLID DRILLS



Viz strana 48 / See page 48

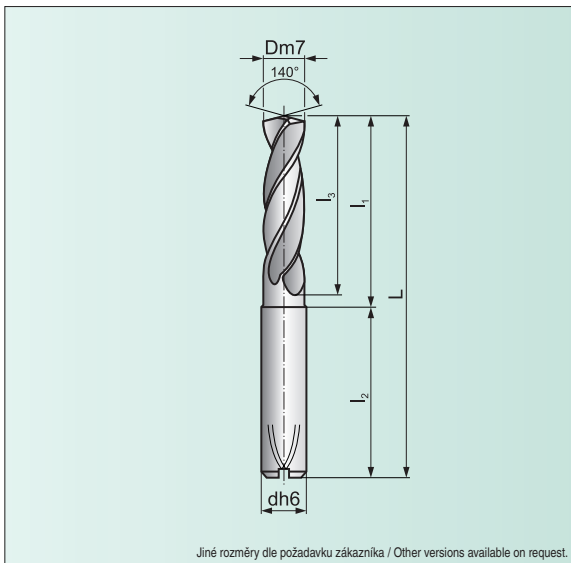

Jiné rozměry dle požadavku zákazníka / Other versions available on request.



● Doporučené použití / Recommended application

● Možné použití (více str.52) / Possible applications (see more on pg. 52)

○ Nedoporučuje se / Not recommended

Dm7		Označení vrtáku Marking of drill	Sortiment/Assortment	Rozměry / Dimensions					-
				L	l ₁	l ₂	l ₃	dh6	
3,0	23	305DA-3,0-21-A06	●	66	30	36	28	6	-
3,1	23	305DA-3,1-21-A06	●	66	30	36	28	6	-
3,2	23	305DA-3,2-21-A06	●	66	30	36	28	6	-
3,3	23	305DA-3,3-21-A06	●	66	30	36	28	6	-
3,4	23	305DA-3,4-21-A06	●	66	30	36	28	6	-
3,5	23	305DA-3,5-21-A06	●	66	30	36	28	6	-
3,6	23	305DA-3,6-24-A06	●	66	30	36	28	6	-
3,7	23	305DA-3,7-24-A06	●	66	30	36	28	6	-
3,8	29	305DA-3,8-24-A06	●	74	38	36	36	6	-
3,9	29	305DA-3,9-24-A06	●	74	38	36	36	6	-
4,0	29	305DA-4,0-26-A06	●	74	38	36	36	6	-
4,1	29	305DA-4,1-26-A06	●	74	38	36	36	6	-
4,2	29	305DA-4,2-26-A06	●	74	38	36	36	6	-
4,3	29	305DA-4,3-26-A06	●	74	38	36	36	6	-
4,4	29	305DA-4,4-26-A06	●	74	38	36	36	6	-
4,5	29	305DA-4,5-28-A06	●	74	38	36	36	6	-
4,6	29	305DA-4,6-28-A06	●	74	38	36	36	6	-
4,7	29	305DA-4,7-30-A06	●	74	38	36	36	6	-
4,8	35	305DA-4,8-30-A06	●	82	46	36	44	6	-
4,9	35	305DA-4,9-30-A06	●	82	46	36	44	6	-
5,0	35	305DA-5,0-35-A06	●	82	46	36	44	6	-

● Skladovaný / Stock Assort. ○ Neskladovaný / Non-stock assort.

Všechny rozměry v [mm] / All dimensions [mm]

Dm7		Označení vrtáku Marking of drill	Soliment/ Assortment	Rozměry / Dimensions					-
				L	l ₁	l ₂	l ₃	dh6	
5,1	35	305DA-5,1-35-A06	●	82	46	36	44	6	-
5,2	35	305DA-5,2-35-A06	●	82	46	36	44	6	-
5,3	35	305DA-5,3-35-A06	●	82	46	36	44	6	-
5,4	35	305DA-5,4-35-A06	●	82	46	36	44	6	-
5,5	35	305DA-5,5-35-A06	●	82	46	36	44	6	-
5,6	35	305DA-5,6-35-A06	●	82	46	36	44	6	-
5,7	35	305DA-5,7-35-A06	●	82	46	36	44	6	-
5,8	35	305DA-5,8-35-A06	●	82	46	36	44	6	-
5,9	35	305DA-5,9-35-A06	●	82	46	36	44	6	-
6,0	35	305DA-6,0-35-A06	●	82	46	36	44	6	-
6,1	43	305DA-6,1-43-A08	●	91	55	36	53	8	-
6,2	43	305DA-6,2-43-A08	●	91	55	36	53	8	-
6,3	43	305DA-6,3-43-A08	●	91	55	36	53	8	-
6,4	43	305DA-6,4-43-A08	●	91	55	36	53	8	-
6,5	43	305DA-6,5-43-A08	●	91	55	36	53	8	-
6,6	43	305DA-6,6-43-A08	●	91	55	36	53	8	-
6,7	43	305DA-6,7-43-A08	●	91	55	36	53	8	-
6,8	43	305DA-6,8-43-A08	●	91	55	36	53	8	-
6,9	43	305DA-6,9-43-A08	●	91	55	36	53	8	-
7,0	43	305DA-7,0-43-A08	●	91	55	36	53	8	-
7,1	43	305DA-7,1-43-A08	●	91	55	36	53	8	-
7,2	43	305DA-7,2-43-A08	●	91	55	36	53	8	-
7,3	43	305DA-7,3-43-A08	●	91	55	36	53	8	-
7,4	43	305DA-7,4-43-A08	●	91	55	36	53	8	-
7,5	43	305DA-7,5-43-A08	●	91	55	36	53	8	-
7,6	43	305DA-7,6-43-A08	●	91	55	36	53	8	-
7,7	43	305DA-7,7-43-A08	●	91	55	36	53	8	-
7,8	43	305DA-7,8-43-A08	●	91	55	36	53	8	-
7,9	43	305DA-7,9-43-A08	●	91	55	36	53	8	-
8,0	43	305DA-8,0-43-A08	●	91	55	36	53	8	-
8,1	49	305DA-8,1-49-A10	●	103	63	40	61	10	-
8,2	49	305DA-8,2-49-A10	●	103	63	40	61	10	-
8,3	49	305DA-8,3-49-A10	●	103	63	40	61	10	-
8,4	49	305DA-8,4-49-A10	●	103	63	40	61	10	-
8,5	49	305DA-8,5-49-A10	●	103	63	40	61	10	-
8,6	49	305DA-8,6-49-A10	●	103	63	40	61	10	-
8,7	49	305DA-8,7-49-A10	●	103	63	40	61	10	-
8,8	49	305DA-8,8-49-A10	●	103	63	40	61	10	-
8,9	49	305DA-8,9-49-A10	●	103	63	40	61	10	-
9,0	49	305DA-9,0-49-A10	●	103	63	40	61	10	-
9,1	49	305DA-9,1-49-A10	●	103	63	40	61	10	-
9,2	49	305DA-9,2-49-A10	●	103	63	40	61	10	-
9,3	49	305DA-9,3-49-A10	●	103	63	40	61	10	-
9,4	49	305DA-9,4-49-A10	●	103	63	40	61	10	-
9,5	49	305DA-9,5-49-A10	●	103	63	40	61	10	-

pokračování na další straně / continues on next page...

● Skladovaný / Stock Assort. ○ Neskladovaný / Non-stock assort.

Všechny rozměry v [mm] / All dimensions [mm]

TYP/TYPE 305DA

MONOLITNÍ VRTÁKY SOLID DRILLS



Viz strana 48 / See page 48

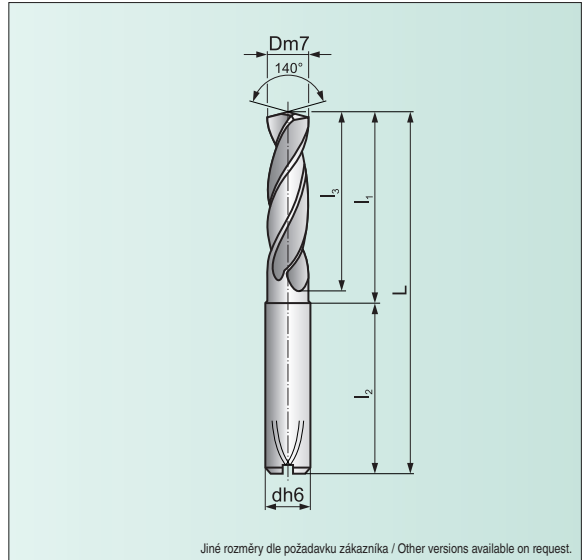

Jiné rozměry dle požadavku zákazníka / Other versions available on request.

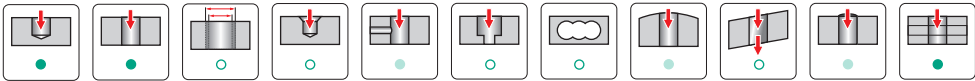

● Doporučené použití / Recommended application

● Možné použití (více str.52) / Possible applications (see more on pg. 52)

○ Nedoporučuje se / Not recommended

Dm7	h	Označení vrtáku Marking of drill	Sortiment/Assortment	Rozměry / Dimensions					-
				L	l ₁	l ₂	l ₃	dh6	
...pokračování z předchozí strany / continues from previous page									
9,6	49	305DA-9,6-49-A10	●	103	63	40	61	10	-
9,7	49	305DA-9,7-49-A10	●	103	63	40	61	10	-
9,8	49	305DA-9,8-49-A10	●	103	63	40	61	10	-
9,9	49	305DA-9,9-49-A10	●	103	63	40	61	10	-
10,0	49	305DA-10,0-49-A10	●	103	63	40	61	10	-
10,2	56	305DA-10,2-56-A12	●	118	73	45	71	12	-
10,5	56	305DA-10,5-56-A12	●	118	73	45	71	12	-
10,8	56	305DA-10,8-56-A12	●	118	73	45	71	12	-
11,0	56	305DA-11,0-56-A12	●	118	73	45	71	12	-
11,2	56	305DA-11,2-56-A12	●	118	73	45	71	12	-
11,3	56	305DA-11,3-56-A12	●	118	73	45	71	12	-
11,5	56	305DA-11,5-56-A12	●	118	73	45	71	12	-
11,8	56	305DA-11,8-56-A12	●	118	73	45	71	12	-
12,0	56	305DA-12,0-56-A12	●	118	73	45	71	12	-
12,2	60	305DA-12,2-60-A14	●	124	79	45	77	14	-
12,5	60	305DA-12,5-60-A14	●	124	79	45	77	14	-
12,8	60	305DA-12,8-60-A14	●	124	79	45	77	14	-
13,0	60	305DA-13,0-60-A14	●	124	79	45	77	14	-
13,3	60	305DA-13,3-60-A14	●	124	79	45	77	14	-
13,5	60	305DA-13,5-60-A14	●	124	79	45	77	14	-

● Skladovaný / Stock Assort. ○ Neskladovaný / Non-stock assort.

Všechny rozměry v [mm] / All dimensions [mm]

Dm7		Označení vrtáku Marking of drill	Sortiment/ Assortment	Rozměry / Dimensions					-
				L	l ₁	l ₂	l ₃	dh6	
13,8	60	305DA-13,8-60-A14	●	124	79	45	77	14	-
14,0	60	305DA-14,0-60-A14	●	124	79	45	77	14	-
14,5	63	305DA-14,5-63-A16	●	133	85	48	83	16	-
15,0	63	305DA-15,0-63-A16	●	133	85	48	83	16	-
15,3	63	305DA-15,3-63-A16	●	133	85	48	83	16	-
15,5	63	305DA-15,5-63-A16	●	133	85	48	83	16	-
15,8	63	305DA-15,8-63-A16	●	133	85	48	83	16	-
16,0	63	305DA-16,0-63-A16	●	133	85	48	83	16	-
16,5	71	305DA-16,5-71-A18	●	143	95	48	93	18	-
17,0	71	305DA-17,0-71-A18	●	143	95	48	93	18	-
17,5	71	305DA-17,5-71-A18	●	143	95	48	93	18	-
18,0	71	305DA-18,0-71-A18	●	143	95	48	93	18	-
18,5	77	305DA-18,5-77-A20	●	153	103	50	101	20	-
19,0	77	305DA-19,0-77-A20	●	153	103	50	101	20	-
19,5	77	305DA-19,5-77-A20	●	153	103	50	101	20	-
20,0	77	305DA-20,0-77-A20	●	153	103	50	101	20	-

● Skladovaný / Stock Assort. ○ Neskladovaný / Non-stock assort.

Všechny rozměry v [mm] / All dimensions [mm]

TYP/TYPE 308FA

MONOLITNÍ VRTÁKY ČTYŘFAZETKOVÉ SOLID DRILLS WITH 4 LAND MARGINS

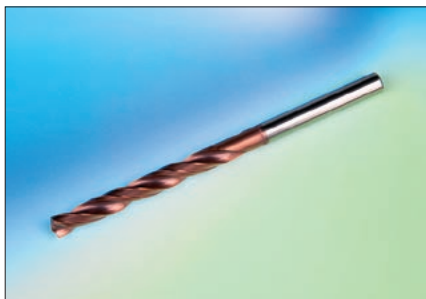

Viz strana 49 / See page 49

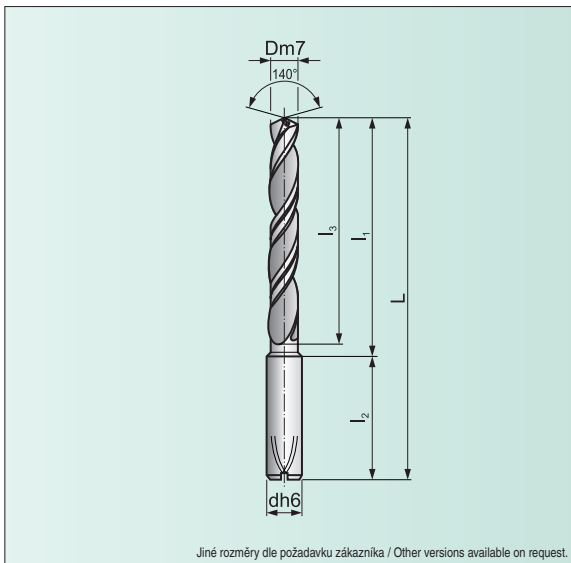

● Doporučené použití / Recommended application

○ Možné použití (více str.52) / Possible applications (see more on pg. 52)

○ Nedoporučuje se / Not recommended

Dm7	h	Označení vrtáku Marking of drill	Sortiment/Assortment	Rozměry / Dimensions					-
				L	l ₁	l ₂	l ₃	dh6	
3,0	32	308FA-3,0-32-A06	●	85	49	36	40	6	-
3,1	32	308FA-3,1-32-A06	●	85	49	36	40	6	-
3,2	32	308FA-3,2-32-A06	●	85	49	36	40	6	-
3,3	32	308FA-3,3-32-A06	●	85	49	36	40	6	-
3,4	32	308FA-3,4-32-A06	○	85	49	36	40	6	-
3,5	32	308FA-3,5-32-A06	○	85	49	36	40	6	-
3,6	36	308FA-3,6-36-A06	○	85	49	36	40	6	-
3,7	36	308FA-3,7-36-A06	○	85	49	36	40	6	-
3,8	36	308FA-3,8-36-A06	○	85	49	36	40	6	-
3,9	36	308FA-3,9-36-A06	○	85	49	36	40	6	-
4,0	38	308FA-4,0-38-A06	●	85	49	36	46	6	-
4,1	38	308FA-4,1-38-A06	○	85	49	36	46	6	-
4,2	38	308FA-4,2-38-A06	●	85	49	36	46	6	-
4,3	40	308FA-4,3-40-A06	○	97	61	36	46	6	-
4,4	40	308FA-4,4-40-A06	○	97	61	36	46	6	-
4,5	44	308FA-4,5-44-A06	●	97	61	36	46	6	-
4,6	44	308FA-4,6-44-A06	●	97	61	36	46	6	-
4,7	44	308FA-4,7-44-A06	○	97	61	36	46	6	-
4,8	44	308FA-4,8-44-A06	●	97	61	36	46	6	-
4,9	44	308FA-4,9-44-A06	○	97	61	36	46	6	-
5,0	48	308FA-5,0-48-A06	●	97	61	36	57	6	-

● Skladovaný / Stock Assort. ○ Neskladovaný / Non-stock assort.

Všechny rozměry v [mm] / All dimensions [mm]

Dm7		Označení vrtáku Marking of drill	Sortiment / Assortment	Rozměry / Dimensions					-
				L	l ₁	l ₂	l ₃	dh6	
5,1	48	308FA-5,1-48-A06	●	97	61	36	57	6	-
5,2	48	308FA-5,2-48-A06	●	97	61	36	57	6	-
5,3	48	308FA-5,3-48-A06	○	97	61	36	57	6	-
5,4	48	308FA-5,4-48-A06	○	97	61	36	57	6	-
5,5	48	308FA-5,5-48-A06	●	97	61	36	57	6	-
5,6	48	308FA-5,6-48-A06	○	97	61	36	57	6	-
5,7	48	308FA-5,7-48-A06	○	97	61	36	57	6	-
5,8	48	308FA-5,8-48-A06	●	97	61	36	57	6	-
5,9	48	308FA-5,9-48-A06	○	97	61	36	57	6	-
6,0	48	308FA-6,0-48-A06	●	97	61	36	57	6	-
6,1	64	308FA-6,1-64-A08	○	116	80	36	76	8	-
6,2	64	308FA-6,2-64-A08	○	116	80	36	76	8	-
6,3	64	308FA-6,3-64-A08	○	116	80	36	76	8	-
6,4	64	308FA-6,4-64-A08	○	116	80	36	76	8	-
6,5	64	308FA-6,5-64-A08	●	116	80	36	76	8	-
6,6	64	308FA-6,6-64-A08	○	116	80	36	76	8	-
6,7	64	308FA-6,7-64-A08	○	116	80	36	76	8	-
6,8	64	308FA-6,8-64-A08	●	116	80	36	76	8	-
6,9	64	308FA-6,9-64-A08	●	116	80	36	76	8	-
7,0	64	308FA-7,0-64-A08	●	116	80	36	76	8	-
7,1	64	308FA-7,1-64-A08	○	116	80	36	76	8	-
7,2	64	308FA-7,2-64-A08	○	116	80	36	76	8	-
7,3	64	308FA-7,3-64-A08	○	116	80	36	76	8	-
7,4	64	308FA-7,4-64-A08	○	116	80	36	76	8	-
7,5	64	308FA-7,5-64-A08	●	116	80	36	76	8	-
7,6	64	308FA-7,6-64-A08	○	116	80	36	76	8	-
7,7	64	308FA-7,7-64-A08	○	116	80	36	76	8	-
7,8	64	308FA-7,8-64-A08	●	116	80	36	76	8	-
7,9	64	308FA-7,9-64-A08	○	116	80	36	76	8	-
8,0	64	308FA-8,0-64-A08	●	116	80	36	76	8	-
8,1	80	308FA-8,1-80-A10	○	142	102	40	95	10	-
8,2	80	308FA-8,2-80-A10	○	142	102	40	95	10	-
8,3	80	308FA-8,3-80-A10	○	142	102	40	95	10	-
8,4	80	308FA-8,4-80-A10	○	142	102	40	95	10	-
8,5	80	308FA-8,5-80-A10	●	142	102	40	95	10	-
8,6	80	308FA-8,6-80-A10	●	142	102	40	95	10	-
8,7	80	308FA-8,7-80-A10	●	142	102	40	95	10	-
8,8	80	308FA-8,8-80-A10	●	142	102	40	95	10	-
8,9	80	308FA-8,9-80-A10	○	142	102	40	95	10	-
9,0	80	308FA-9,0-80-A10	●	142	102	40	95	10	-
9,1	80	308FA-9,1-80-A10	○	142	102	40	95	10	-
9,2	80	308FA-9,2-80-A10	○	142	102	40	95	10	-
9,3	80	308FA-9,3-80-A10	○	142	102	40	95	10	-
9,4	80	308FA-9,4-80-A10	○	142	102	40	95	10	-
9,5	80	308FA-9,5-80-A10	●	142	102	40	95	10	-

pokračování na další straně / continues on next page...

● Skladovaný / Stock Assort. ○ Neskladovaný / Non-stock assort.

Všechny rozměry v [mm] / All dimensions [mm]

TYP/TYPE 308FA

MONOLITNÍ VRTÁKY ČTYŘFAZETKOVÉ SOLID DRILLS WITH 4 LAND MARGINS

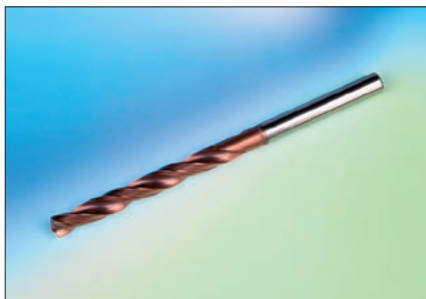

Viz strana 49 / See page 49

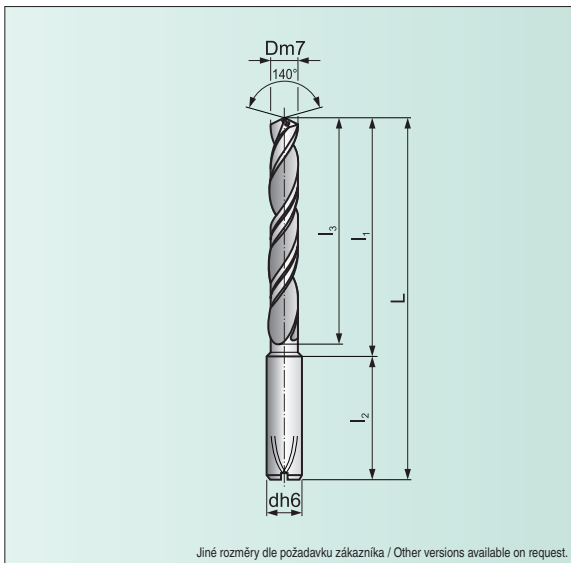

Jiné rozměry dle požadavku zákazníka / Other versions available on request.



● Doporučené použití / Recommended application

● Možné použití (více str.52) / Possible applications (see more on pg. 52)

○ Nedoporučuje se / Not recommended

Dm7	h	Označení vrtáku Marking of drill	Sortiment/Assortment	Rozměry / Dimensions					-
				L	L ₁	L ₂	L ₃	dh6	
...pokračování z předchozí strany / continues from previous page									
9,6	80	308FA-9,6-80-A10	○	142	102	40	95	10	-
9,7	80	308FA-9,7-80-A10	○	142	102	40	95	10	-
9,8	80	308FA-9,8-80-A10	●	142	102	40	95	10	-
9,9	80	308FA-9,9-80-A10	○	142	102	40	95	10	-
10,0	80	308FA-10,0-80-A10	●	142	102	40	95	10	-
10,2	96	308FA-10,2-96-A12	●	163	118	45	114	12	-
10,5	96	308FA-10,5-96-A12	●	163	118	45	114	12	-
10,8	96	308FA-10,8-96-A12	●	163	118	45	114	12	-
11,0	96	308FA-11,0-96-A12	●	163	118	45	114	12	-
11,2	96	308FA-11,2-96-A12	○	163	118	45	114	12	-
11,3	96	308FA-11,3-96-A12	○	163	118	45	114	12	-
11,5	96	308FA-11,5-96-A12	●	163	118	45	114	12	-
11,8	96	308FA-11,8-96-A12	●	163	118	45	114	12	-
12,0	96	308FA-12,0-96-A12	●	163	118	45	114	12	-
12,2	112	308FA-12,2-112-A14	○	182	137	45	133	14	-
12,5	112	308FA-12,5-112-A14	●	182	137	45	133	14	-
12,8	112	308FA-12,8-112-A14	●	182	137	45	133	14	-
13,0	112	308FA-13,0-112-A14	●	182	137	45	133	14	-
13,5	112	308FA-13,5-112-A14	●	182	137	45	133	14	-
14,0	112	308FA-14,0-112-A14	●	182	137	45	133	14	-

● Skladovaný / Stock Assort. ○ Neskladovaný / Non-stock assort.

Všechny rozměry v [mm] / All dimensions [mm]

Dm7		Označení vrtáku Marking of drill	Sortiment / Assortment	Rozměry / Dimensions					-
				L	l ₁	l ₂	l ₃	dh6	
14,5	128	308FA-14,5-128-A16	●	204	156	48	152	16	-
15,0	128	308FA-15,0-128-A16	●	204	156	48	152	16	-
15,5	128	308FA-15,5-128-A16	●	204	156	48	152	16	-
16,0	128	308FA-16,0-128-A16	●	204	156	48	152	16	-

OBSAH
CONTENT

MONOLITNÍ VRTÁKY
SOLID DRILLS

DESTIČKOVÉ VRTÁKY
INDEXABLE DRILLS

VYMĚNITELNÉ DESTIČKY
INDEXABLE INSERTS

NASTAVITELNÉ POUZDRO
ADJUSTABLE SLEEVE

ŘEZNÉ PODMÍNKY
CUTTING CONDITIONS

TECHNICKÁ ČÁST
TECHNICAL PART

● Skladovaný / Stock Assort. ○ Neskladovaný / Non-stock assort.

Všechny rozměry v [mm] / All dimensions [mm]

TYP/TYPE 303TA

STUPŇOVITÉ VRTÁKY STEP DRILLS



Viz strana 48 / See page 48

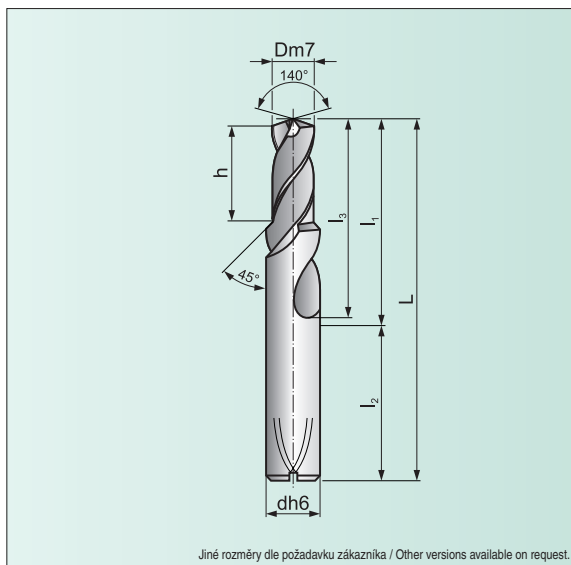

Jiné rozměry dle požadavku zákazníka / Other versions available on request.

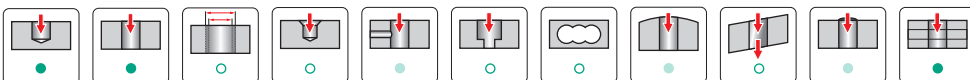

● Doporučené použití / Recommended application

○ Možné použití (více str.52) / Possible applications (see more on pg. 52)

○ Nedoporučuje se / Not recommended

Dm7		Označení vrtáku Marking of drill	Sortiment/Assortment	Rozměry / Dimensions					Závít Thread
				L	l ₁	l ₂	l ₃	dh6	
3,3	11,4	303TA-3,3-11,4-C45A06	●	66	30	36	20	6	M4
3,4	11,4	303TA-3,4-11,4-C45A06	●	66	30	36	20	6	M4
4,2	13,6	303TA-4,2-13,6-C45A06	●	66	30	36	24	6	M5
4,3	13,6	303TA-4,3-13,6-C45A06	●	66	30	36	24	6	M5
5,0	16,5	303TA-5,0-16,5-C45A08	●	79	43	36	28	8	M6
5,1	16,5	303TA-5,1-16,5-C45A08	●	79	43	36	28	8	M6
6,8	21,0	303TA-6,8-21,0-C45A10	●	89	49	40	34	10	M8
6,9	21,0	303TA-6,9-21,0-C45A10	●	89	49	40	34	10	M8
8,5	25,5	303TA-8,5-25,5-C45A12	●	102	57	45	47	12	M10
8,7	25,5	303TA-8,7-25,5-C45A12	●	102	57	45	47	12	M10
10,2	30,0	303TA-10,2-30,0-C45A14	●	107	62	45	55	14	M12
10,4	30,0	303TA-10,4-30,0-C45A14	●	107	62	45	55	14	M12
12,0	34,5	303TA-12,0-34,5-C45A16	●	115	67	48	60	16	M14
12,25	34,5	303TA-12,25-34,5-C45A16	○	115	67	48	60	16	M14
14,0	38,5	303TA-14,0-38,5-C45A18	●	123	75	48	65	18	M16
14,25	38,5	303TA-14,25-38,5-C45A18	●	123	75	48	65	18	M16
7,0	21,0	303TA-7,0-21,0-C45A10	○	89	49	40	34	10	M8x1,0
9,0	25,5	303TA-9,0-25,5-C45A12	○	102	57	45	47	12	M10x1,0
10,5	30,0	303TA-10,5-30,0-C45A14	○	107	62	45	55	14	M12x1,5
12,5	34,5	303TA-12,5-34,5-C45A16	○	115	67	48	60	16	M14x1,5
14,5	38,5	303TA-14,5-38,5-C45A18	○	123	75	48	65	18	M16x1,5

● Skladovaný / Stock Assort.

○ Neskladovaný / Non-stock assort.

Všechny rozměry v [mm] / All dimensions [mm]

TYP/TYPE 802D

VRTÁKY S VYMĚNITELNÝMI BŘITOVÝMI DESTIČKAMI INDEXABLE INSERT DRILLS



Viz strana 42 / See page 42

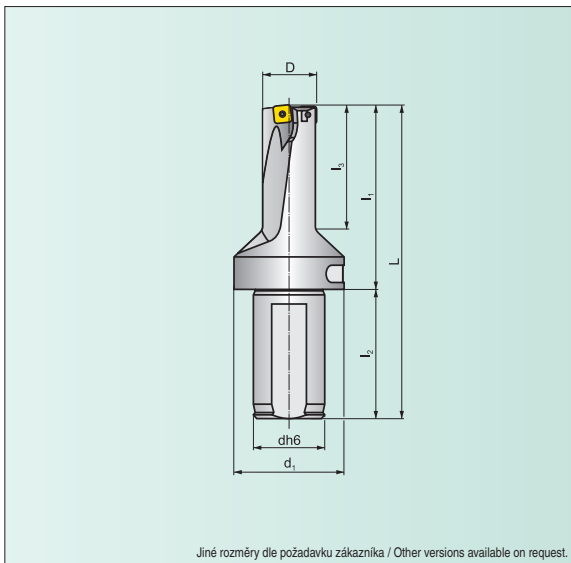

Jiné rozměry dle požadavku zákazníka / Other versions available on request.

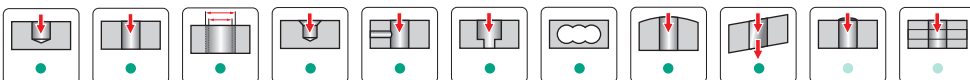

● Doporučené použití / Recommended application

● Možné použití (více str.52) / Possible applications (see more on pg. 52)

○ Nedoporučuje se / Not recommended

D	h	Označení vrtáku Marking of drill	Sortiment/Assortment	Rozměry / Dimensions						Středová destička Centre insert	Obvodová destička Peripheral insert	Radiální nastavení Radial adjustment	
				L	L ₁	L ₂	L ₃	dh6	d ₁			-	+
15	30	802D-15	●	121,0	65,0	56	34,5	25	45	0502AP	0502..	0,30	0,30
16	32	802D-16	●	123,0	67,0	56	37,0	25	45	0502AP	0502..	0,15	0,40
17	34	802D-17	●	125,0	69,0	56	39,5	25	45	0502AP	0502..	0,15	0,50
18	36	802D-18	●	127,0	71,0	56	42,0	25	45	0602AP	0502..	0,35	0,20
19	38	802D-19	●	129,0	73,0	56	44,5	25	45	0602AP	0602..	0,30	0,35
20	40	802D-20	●	131,0	75,0	56	47,0	25	45	0602AP	0602..	0,20	0,50
21	42	802D-21	●	133,0	77,0	56	49,5	25	45	0602AP	0602..	0,10	0,50
22	44	802D-22	●	135,0	79,0	56	52,0	25	45	0703AP	0602..	0,50	0,40
23	46	802D-23	●	137,0	81,0	56	54,5	25	45	0703AP	0703..	0,50	0,50
24	48	802D-24	●	139,0	83,0	56	57,0	25	45	0703AP	0703..	0,50	0,50
25	50	802D-25	●	145,0	85,0	60	57,0	32	50	0703AP	0703..	0,30	0,50
26	52	802D-26	●	147,0	87,0	60	59,5	32	50	0703AP	0703..	0,10	0,50
27	54	802D-27	●	149,0	89,0	60	62,0	32	50	0903AP	0703..	0,50	0,20
28	56	802D-28	●	151,0	91,0	60	64,5	32	50	0903AP	09T3..	0,50	0,35
29	58	802D-29	●	153,0	93,0	60	67,0	32	50	0903AP	09T3..	0,50	0,50
30	60	802D-30	●	155,0	95,0	60	69,5	32	50	0903AP	09T3..	0,35	0,50
32	64	802D-32	●	167,0	99,0	68	70,0	40	59	0903AP	09T3..	0,15	0,50
32	64	802D-32-S32	●	159,0	99,0	60	70,0	32	59	0903AP	09T3..	0,15	0,50
34	68	802D-34	●	171,0	103,0	68	75,0	40	59	11T3AP	09T3..	0,50	0,50
34	68	802D-34-S32	●	163,0	103,0	60	75,0	32	59	11T3AP	09T3..	0,50	0,50
36	72	802D-36	●	173,0	105,0	68	77,5	40	59	11T3AP	1204..	0,10	0,50

● Skladovaný / Stock Assort.

○ Neskladovaný / Non-stock assort.

Všechny rozměry v [mm] / All dimensions [mm]

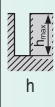
D		Označení vrtáku Marking of drill	Sortiment/Assortment	Rozměry / Dimensions						Středová destička Centre insert	Obvodová destička Peripheral insert	Radiální nastavení Radial adjustment	
				L	l ₁	l ₂	l ₃	dh6	d ₁	XPET	SCET	-	+
36	72	802D-36-S32	●	167,0	107,0	60	80,0	32	59	11T3AP	1204..	0,10	0,50
38	76	802D-38	●	179,0	111,0	68	85,0	40	59	11T3AP	1204..	0,15	0,50
38	76	802D-38-S32	●	171,0	111,0	60	85,0	32	59	11T3AP	1204..	0,15	0,50
40	80	802D-40	●	183,0	115,0	68	90,0	40	59	12T3AP	1204..	0,35	0,50
40	80	802D-40-S32	●	175,0	115,0	60	90,0	32	59	12T3AP	1204..	0,35	0,50

NÁHRADNÍ DÍLY / SPARE PARTS

Vrták Drill	Upínací šroub - vnitřní VBD Clamping screw - internal insert	Upínací šroub - vnější VBD Clamping screw - external insert	Šroubovák Screwdriver
∅15 ÷ ∅17	US 2245-T07P	US 2245-T07P	SDR T07P
∅17,5 ÷ ∅18,5	US 2205-T07P	US 2245-T07P	SDR T07P
∅19 ÷ ∅21	US 2205-T07P	US 2205-T07P	SDR T07P
∅21,5 ÷ ∅22	US 2506-T07P	US 2506-T07P	SDR T07P
∅22,5 ÷ ∅26	US 2507-T08P	US 3007-T08P	SDR T08P
∅26,5 ÷ ∅27	US 3007-T09P	US 3007-T09P	SDR T09P
∅28 ÷ ∅32	US 3007-T09P	US 3009-T09P	SDR T09P
∅33 ÷ ∅34	US 3508-T15P	US 3508-T15P	SDR T15P
∅35 ÷ ∅40	US 3508-T15P	US 5012-T15P	SDR T15P

TYP/TYPE 803D

VRTÁKY S VYMĚNITELNÝMI BŘITOVÝMI DESTIČKAMI INDEXABLE INSERT DRILLS



Viz strana 42 / See page 42

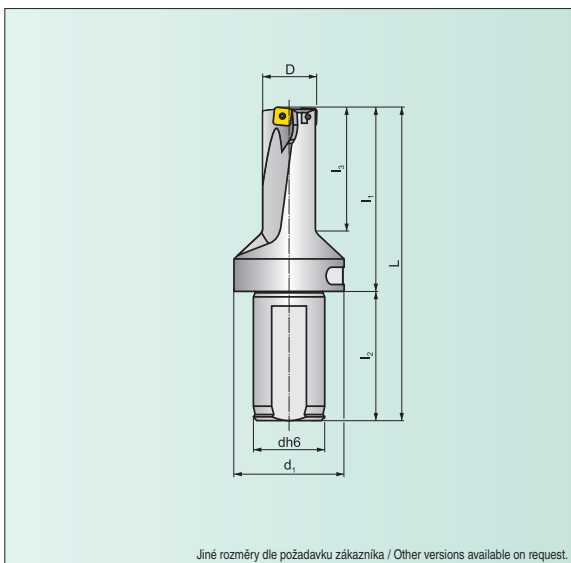

Jiné rozměry dle požadavku zákazníka / Other versions available on request.

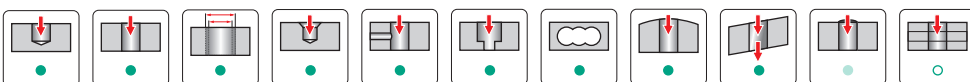

● Doporučené použití / Recommended application

● Možné použití (více str.52) / Possible applications (see more on pg. 52)

○ Nedoporučuje se / Not recommended

D	h	Označení vrtáku Marking of drill	Sortiment/Assortment	Rozměry / Dimensions						Středová destička Centre insert	Obvodová destička Peripheral insert	Radiální nastavení Radial adjustment	
				L	L ₁	L ₂	L ₃	dh6	d ₁			-	+
15	45	803D-15	●	136,0	80,0	56	49,5	25	45	0502AP	0502..	0,30	0,15
15,5	47	803D-15,5	●	137,5	81,5	56	51,2	25	45	0502AP	0502..	0,35	0,15
16	48	803D-16	●	139,0	83,0	56	53,0	25	45	0502AP	0502..	0,30	0,30
16,5	50	803D-16,5	●	140,5	84,5	56	54,7	25	45	0502AP	0502..	0,35	0,30
17	51	803D-17	●	142,0	86,0	56	56,5	25	45	0502AP	0502..	0,15	0,35
17,5	53	803D-17,5	●	143,5	87,5	56	58,2	25	45	0602AP	0502..	0,15	0,35
18	54	803D-18	●	145,0	89,0	56	60,0	25	45	0602AP	0502..	0,35	0,15
18,5	56	803D-18,5	●	146,5	90,5	56	61,2	25	45	0602AP	0502..	0,35	0,15
19	57	803D-19	●	148,0	92,0	56	63,5	25	45	0602AP	0602..	0,30	0,20
19,5	59	803D-19,5	●	149,5	93,5	56	63,7	25	45	0602AP	0602..	0,35	0,20
20	60	803D-20	●	151,0	95,0	56	67,0	25	45	0602AP	0602..	0,30	0,35
20,5	62	803D-20,5	●	152,5	96,5	56	67,2	25	45	0602AP	0602..	0,20	0,35
21	63	803D-21	●	154,0	98,0	56	70,5	25	45	0602AP	0602..	0,10	0,50
21,5	65	803D-21,5	●	155,5	99,5	56	70,8	25	45	0703AP	0602..	0,35	0,25
22	66	803D-22	●	157,0	101,0	56	74,0	25	45	0703AP	0602..	0,50	0,25
22,5	68	803D-22,5	●	158,5	102,5	56	74,3	25	45	0703AP	0703..	0,35	0,40
23	69	803D-23	●	160,0	104,0	56	77,5	25	45	0703AP	0703..	0,50	0,40
23,5	71	803D-23,5	●	161,5	105,5	56	77,6	25	45	0703AP	0703..	0,25	0,40
24	72	803D-24	●	163,0	107,0	56	81,0	25	45	0703AP	0703..	0,50	0,45
24,5	74	803D-24,5	●	168,5	108,5	60	78,7	32	50	0703AP	0703..	0,35	0,40
25	75	803D-25	●	170,0	110,0	60	82,0	32	50	0703AP	0703..	0,30	0,50

● Skladovaný / Stock Assort.

○ Neskladovaný / Non-stock assort.

Všechny rozměry v [mm] / All dimensions [mm]

D		Označení vrtáku Marking of drill	Sortiment/Assortment	Rozměry / Dimensions						Středová destička Centre insert XPET	Obvodová destička Peripheral insert SCET	Radiální nastavení Radial adjustment	
				L	l ₁	l ₂	l ₃	dh6	d ₁			-	+
25,5	77	803D-25,5	●	171,5	111,5	60	82,2	32	50	0703AP	0703..	0,20	0,50
26	78	803D-26	●	173,0	113,0	60	85,5	32	50	0703AP	0703..	0,20	0,50
26,5	80	803D-26,5	●	174,5	114,5	60	85,7	32	50	0903AP	0703..	0,35	0,25
27	81	803D-27	●	176,0	116,0	60	89,0	32	50	0903AP	0703..	0,50	0,20
28	84	803D-28	●	179,0	119,0	60	92,5	32	50	0903AP	09T3..	0,50	0,35
29	87	803D-29	●	182,0	122,0	60	96,0	32	50	0903AP	09T3..	0,50	0,45
30	90	803D-30	●	185,0	125,0	60	99,5	32	50	0903AP	09T3..	0,35	0,50
31	93	803D-31	●	188,0	128,0	60	103,0	32	50	0903AP	09T3..	0,20	0,50
32	96	803D-32	●	199,0	131,0	68	102,0	40	59	0903AP	09T3..	0,10	0,50
32	96	803D-32-S32	●	191,0	131,0	60	102,0	32	59	0903AP	09T3..	0,10	0,50
33	99	803D-33	●	202,0	134,0	68	105,5	40	59	11T3AP	09T3..	0,50	0,40
33	99	803D-33-S32	●	194,0	134,0	60	105,5	32	59	11T3AP	09T3..	0,50	0,40
34	102	803D-34	●	205,0	137,0	68	109,0	40	59	11T3AP	09T3..	0,50	0,30
34	102	803D-34-S32	●	197,0	137,0	60	109,0	32	59	11T3AP	09T3..	0,50	0,30
35	105	803D-35	●	208,0	140,0	68	112,5	40	59	11T3AP	1204..	0,50	0,40
35	105	803D-35-S32	●	200,0	140,0	60	112,5	32	59	11T3AP	1204..	0,50	0,40
36	108	803D-36	●	211,0	143,0	68	116,0	40	59	11T3AP	1204..	0,40	0,50
36	108	803D-36-S32	●	203,0	143,0	60	116,0	32	59	11T3AP	1204..	0,40	0,50
37	111	803D-37	●	214,0	146,0	68	119,5	40	59	11T3AP	1204..	0,20	0,50
37	111	803D-37-S32	●	206,0	146,0	60	119,5	32	59	11T3AP	1204..	0,20	0,50
38	114	803D-38	●	217,0	149,0	68	123,0	40	59	11T3AP	1204..	0,10	0,50
38	114	803D-38-S32	●	209,0	149,0	60	123,0	32	59	11T3AP	1204..	0,10	0,50
39	117	803D-39	●	220,0	152,0	68	126,5	40	59	12T3AP	1204..	0,50	0,35
39	117	803D-39-S32	●	212,0	152,0	60	126,5	32	59	12T3AP	1204..	0,50	0,35
40	120	803D-40	●	223,0	155,0	68	130,0	40	59	12T3AP	1204..	0,35	0,50
40	120	803D-40-S32	●	215,0	155,0	60	130,0	32	59	12T3AP	1204..	0,35	0,50

NÁHRADNÍ DÍLY / SPARE PARTS

Vrták Drill	Upínací šroub - vnitřní VBD Clamping screw - internal insert	Upínací šroub - vnější VBD Clamping screw - external insert	Šroubovák Screwdriver		
∅15 ÷ ∅17	US 2245-T07P	US 2245-T07P	SDR T07P		
∅17,5 ÷ ∅18,5	US 2205-T07P	US 2245-T07P	SDR T07P		
∅19 ÷ ∅21	US 2205-T07P	US 2205-T07P	SDR T07P		
∅21,5 ÷ ∅22	US 2506-T07P	US 2506-T07P	SDR T07P		
∅22,5 ÷ ∅26,5	US 2507-T08P	US 3007-T08P	SDR T08P		
∅27	US 3007-T09P	US 3007-T09P	SDR T09P		
∅28 ÷ ∅32	US 3007-T09P	US 3009-T09P	SDR T09P		
∅33 ÷ ∅34	US 3508-T15P	US 3508-T15P	SDR T15P		
∅35 ÷ ∅40	US 3508-T15P	US 5012-T15P	SDR T15P		

● Skladovaný / Stock Assort. ○ Neskladovaný / Non-stock assort.

Všechny rozměry v [mm] / All dimensions [mm]

TYP/TYPE 803D

VRTÁKY S VYMĚNITELNÝMI BŘITOVÝMI DESTIČKAMI INDEXABLE INSERT DRILLS



Viz strana 42 / See page 42

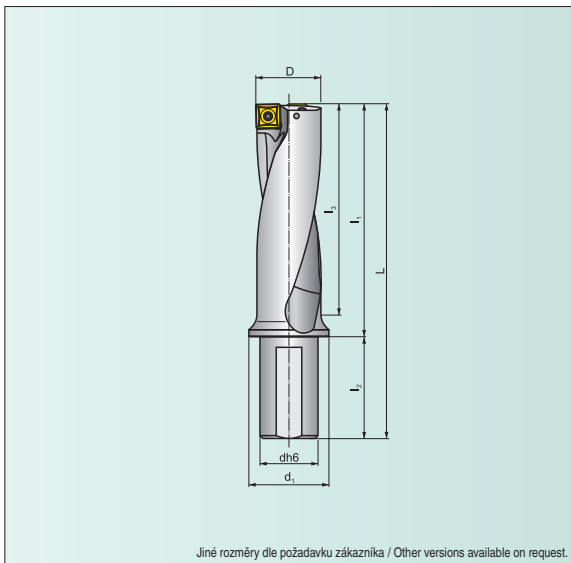

Jiné rozměry dle požadavku zákazníka / Other versions available on request.



● Doporučené použití / Recommended application

○ Možné použití (více str.52) / Possible applications (see more on pg. 52)

○ Nedoporučuje se / Not recommended

D	h	Označení vrtáku Marking of drill	Sortiment/Assortment	Rozměry / Dimensions						Středová destička Centre insert	Obvodová destička Peripheral insert	Radiální nastavení Radial adjustment	
				L	l ₁	l ₂	l ₃	dh6	d ₁			-	+
41	123	803D-41-123-S40	●	219,0	149,0	70	133,0	40	50	12T3AP	1204..	0,20	0,50
42	126	803D-42-126-S40	●	221,5	151,5	70	136,0	40	50	12T3AP	1204..	0,15	0,50
43	129	803D-43-129-S40	●	224,0	154,0	70	139,0	40	50	12T3AP	1204..	0,10	0,50
44	132	803D-44-132-S40	●	226,5	156,5	70	142,0	40	50	1504AP	1204..	0,50	0,50
45	135	803D-45-135-S40	●	230,5	160,5	70	144,0	40	55	1504AP	1505..	0,50	0,50
46	138	803D-46-138-S40	●	235,0	165,0	70	148,0	40	55	1504AP	1505..	0,50	0,50
47	141	803D-47-141-S40	●	237,5	167,5	70	151,0	40	55	1504AP	1505..	0,50	0,50
48	144	803D-48-144-S40	●	240,0	170,0	70	154,0	40	55	1504AP	1505..	0,50	0,50
49	147	803D-49-147-S40	●	242,5	172,5	70	157,0	40	55	1504AP	1505..	0,30	0,50
50	150	803D-50-150-S40	●	246,5	176,5	70	160,0	40	58	1504AP	1505..	0,15	0,50
51	153	803D-51-153-S40	●	249,0	179,0	70	163,0	40	58	1504AP	1505..	0,15	0,50
52	156	803D-52-156-S40	●	251,5	181,5	70	166,0	40	58	1904AP	1505..	0,50	0,50
53	159	803D-53-159-S40	●	254,0	184,0	70	169,0	40	58	1904AP	1505..	0,50	0,50
54	162	803D-54-162-S40	●	257,5	187,5	70	173,0	40	58	1904AP	1505..	0,50	0,50
55	165	803D-55-165-S40	●	260,0	190,0	70	176,0	40	58	1904AP	1505..	0,50	0,50
56	168	803D-56-168-S40	●	264,0	194,0	70	179,0	40	58	1904AP	1505..	0,50	0,50
57	171	803D-57-171-S40	●	266,5	196,5	70	182,0	40	58	1904AP	1505..	0,35	0,50
58	174	803D-58-174-S40	●	270,0	200,0	70	186,0	40	58	1904AP	1505..	0,15	0,50

● Skladovaný / Stock Assort.

○ Neskladovaný / Non-stock assort.

Všechny rozměry v [mm] / All dimensions [mm]

NÁHRADNÍ DÍLY / SPARE PARTS

Vrták Drill	Upínací šroub - vnitřní VBD Clamping screw - internal insert	Upínací šroub - vnější VBD Clamping screw - external insert	Šroubovák Screwdriver		
Ø41 ÷ Ø43	US 3510-T15P	US 5012-T15P	SDR T15P		
Ø44 ÷ Ø58	US 4011-T15P	US 5012-T15P	SDR T15P		

TYP/TYPE 804D

VRTÁKY S VYMĚNITELNÝMI BŘITOVÝMI DESTIČKAMI INDEXABLE INSERT DRILLS



Viz strana 42 / See page 42

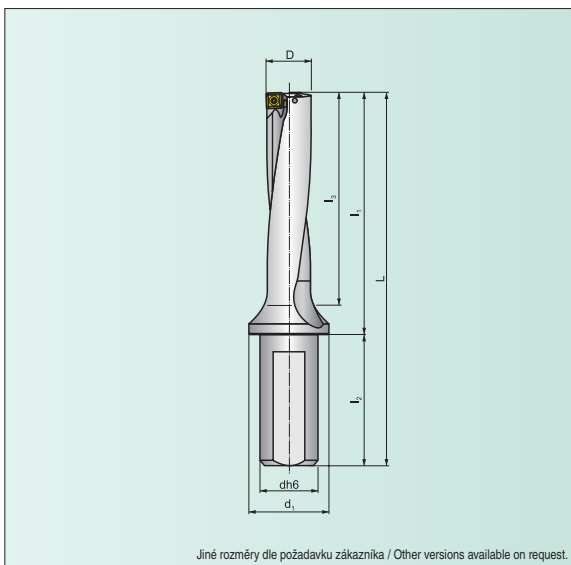

Jiné rozměry dle požadavku zákazníka / Other versions available on request.



● Doporučené použití / Recommended application

● Možné použití (více str.52) / Possible applications (see more on pg. 52)

○ Nedoporučuje se / Not recommended

D	h	Označení vrtáku Marking of drill	Sortiment/Assortment	Rozměry / Dimensions						Středová destička Centre insert	Obvodová destička Peripheral insert	Radiální nastavení Radial adjustment	
				L	l_1	l_2	l_3	dh6	d_1			-	+
17	68	804D-17-68-S25	●	149,0	93,0	56	73,0	25	35	0502AP	0502..	0,10	0,50
18	72	804D-18-72-S25	●	153,0	97,0	56	77,0	25	35	0602AP	0502..	0,35	0,25
19	76	804D-19-76-S25	●	157,0	101,0	56	81,5	25	35	0602AP	0502..	0,15	0,45
20	80	804D-20-80-S25	●	161,0	105,0	56	85,0	25	35	0602AP	0602..	0,10	0,45
21	84	804D-21-84-S25	●	165,0	109,0	56	89,5	25	35	0602AP	0602..	0,10	0,50
22	88	804D-22-88-S25	●	169,0	113,0	56	94,0	25	35	0703AP	0602..	0,45	0,50
23	92	804D-23-92-S25	●	173,0	117,0	56	98,5	25	35	0703AP	0703..	0,35	0,50
24	96	804D-24-96-S25	●	177,0	121,0	56	103,0	25	35	0703AP	0703..	0,15	0,50
25	100	804D-25-100-S32	●	185,0	125,0	60	105,0	32	42	0703AP	0703..	0,15	0,50
26	104	804D-26-104-S32	●	189,0	129,0	60	109,5	32	42	0703AP	0703..	0,10	0,50
27	108	804D-27-108-S32	●	193,0	133,0	60	114,0	32	42	0903AP	0703..	0,50	0,30
28	112	804D-28-112-S32	●	197,0	137,0	60	118,5	32	42	0903AP	09T3..	0,30	0,50
29	116	804D-29-116-S32	●	201,0	141,0	60	123,0	32	42	0903AP	09T3..	0,20	0,50
30	120	804D-30-120-S32	●	205,0	145,0	60	127,5	32	42	0903AP	09T3..	0,15	0,50
31	124	804D-31-124-S32	●	209,0	149,0	60	132,0	32	42	0903AP	09T3..	0,15	0,50
32	128	804D-32-128-S32	●	213,0	153,0	60	136,5	32	42	11T3AP	09T3..	0,50	0,30
33	132	804D-33-132-S32	●	217,0	157,0	60	141,0	32	42	11T3AP	09T3..	0,50	0,50
34	136	804D-34-136-S32	●	221,0	161,0	60	145,5	32	42	11T3AP	09T3..	0,25	0,50
35	140	804D-35-140-S32	●	225,0	165,0	60	149,0	32	42	11T3AP	1204..	0,25	0,50
36	144	804D-36-144-S32	●	229,0	169,0	60	153,5	32	42	11T3AP	1204..	0,10	0,50
37	148	804D-37-148-S32	●	233,0	173,0	60	158,0	32	42	11T3AP	1204..	0,10	0,50



● Skladovaný / Stock Assort.

○ Neskladovaný / Non-stock assort.

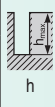
Všechny rozměry v [mm] / All dimensions [mm]

D		Označení vrtáku Marking of drill	Sortiment/Assortment	Rozměry / Dimensions						Středová destička Centre insert XPET	Obvodová destička Peripheral insert SCET	Radiální nastavení Radial adjustment	
				L	l ₁	l ₂	l ₃	dh6	d ₁			-	+
38	152	804D-38-152-S32	●	237,0	177,0	60	162,5	32	42	11T3AP	1204..	0,50	0,50
39	156	804D-39-156-S32	●	241,0	181,0	60	167,0	32	42	12T3AP	1204..	0,40	0,50
40	160	804D-40-160-S32	●	245,0	185,0	60	171,5	32	42	12T3AP	1204..	0,20	0,50

NÁHRADNÍ DÍLY / SPARE PARTS

Vrták Drill	Upínací šroub - vnitřní VBD Clamping screw - internal insert	Upínací šroub - vnější VBD Clamping screw - external insert	Šroubovák Screwdriver		
					
∅15 ÷ ∅17	US 2245-T07P	US 2245-T07P	SDR T07P		
∅17,5 ÷ ∅19	US 2205-T07P	US 2245-T07P	SDR T07P		
∅20 ÷ ∅21	US 2205-T07P	US 2205-T07P	SDR T07P		
∅21,5 ÷ ∅22	US 2506-T07P	US 2506-T07P	SDR T07P		
∅22,5 ÷ ∅26	US 2507-T08P	US 3007-T08P	SDR T08P		
∅26,5 ÷ ∅27	US 3007-T09P	US 3007-T09P	SDR T09P		
∅28 ÷ ∅31	US 3007-T09P	US 3009-T09P	SDR T09P		
∅32 ÷ ∅34	US 3510-T15P	US 3508-T15P	SDR T15P		
∅35 ÷ ∅40	US 3510-T15P	US 5012-T15P	SDR T15P		

● Skladovaný / Stock Assort.

○ Neskladovaný / Non-stock assort.

Všechny rozměry v [mm] / All dimensions [mm]

NÁHRADNÍ DÍLY / SPARE PARTS

Vrták Drill	Upínací šroub - vnitřní VBD Clamping screw - internal insert	Upínací šroub - vnější VBD Clamping screw - external insert	Šroubovák Screwdriver		
Ø15 ÷ Ø17	US 2245-T07P	US 2245-T07P	SDR T07P		
Ø17,5 ÷ Ø19	US 2205-T07P	US 2245-T07P	SDR T07P		
Ø20 ÷ Ø21	US 2205-T07P	US 2205-T07P	SDR T07P		
Ø21,5 ÷ Ø22	US 2506-T07P	US 2506-T07P	SDR T07P		
Ø22,5 ÷ Ø26	US 2507-T08P	US 3007-T08P	SDR T08P		
Ø26,5 ÷ Ø27	US 3007-T09P	US 3007-T09P	SDR T09P		
Ø28 ÷ Ø31	US 3007-T09P	US 3009-T09P	SDR T09P		
Ø32 ÷ Ø34	US 3510-T15P	US 3508-T15P	SDR T15P		
Ø35 ÷ Ø40	US 3510-T15P	US 5012-T15P	SDR T15P		

TYP/TYPE 7720

VRTÁKY S VYMĚNITELNÝMI BŘITOVÝMI DESTIČKAMI INDEXABLE INSERT DRILLS



Viz strana 43 / See page 43

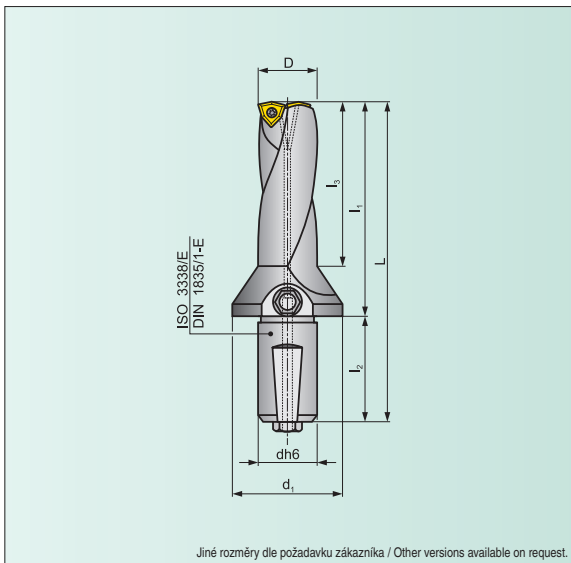

Jiné rozměry dle požadavku zákazníka / Other versions available on request.



● Doporučené použití / Recommended application

● Možné použití (více str.52) / Possible applications (see more on pg. 52)

○ Nedoporučuje se / Not recommended





D	h	Označení vrtáku Marking of drill	Sortiment/Assortment	Rozměry / Dimensions						Středová destička Centre insert	Obvodová destička Peripheral insert	Radiální nastavení Radial adjustment	
				L	L ₁	L ₂	L ₃	dh6	d ₁			WCMT	WCMT
41	102	7720-41	○	215	147	68	105	40	60	0804..	0804..	0,15	0,90
42	102	7720-42	●	215	147	68	105	40	60	0804..	0804..	0,15	0,90
43	107	7720-43	●	220	152	68	110	40	60	0804..	0804..	0,15	0,90
44	107	7720-44	●	220	152	68	110	40	60	0804..	0804..	0,15	0,80
45	112	7720-45	●	225	157	68	115	40	60	0804..	0804..	0,15	0,70
46	112	7720-46	●	225	157	68	115	40	60	0804..	0804..	0,15	0,60
47	117	7720-47	○	230	162	68	120	40	60	0804..	0804..	0,15	0,55
48	117	7720-48	●	230	162	68	120	40	60	0804..	0804..	0,15	0,50
49	122	7720-49	○	235	167	68	125	40	60	0804..	0804..	0,15	0,50
50	122	7720-50	●	235	167	68	125	40	60	0804..	0804..	0,18	0,40
51	127	7720-51	○	240	172	68	130	40	60	0804..	0804..	0,18	0,40
52	127	7720-52	●	240	172	68	130	40	60	0804..	0804..	0,18	0,35
53	133	7720-53	○	245	177	68	135	40	60	0804..	0804..	0,18	0,35
54	133	7720-54	●	245	177	68	135	40	60	0804..	0804..	0,18	0,30
55	137	7720-55	●	250	182	68	140	40	60	0804..	0804..	0,18	0,30
56	137	7720-56	○	250	182	68	140	40	60	0804..	0804..	0,20	0,25
57	142	7720-57	○	255	187	68	145	40	60	0804..	0804..	0,20	0,20
58	142	7720-58	●	255	187	68	145	40	60	0804..	0804..	0,20	0,20

● Skladovaný / Stock Assort.

○ Neskladovaný / Non-stock assort.

Všechny rozměry v [mm] / All dimensions [mm]

NÁHRADNÍ DÍLY / SPARE PARTS

Vrták Drill	Upínací šroub Clamping screw 	Šroubovák Screwdriver 	Zátka Plug 	Přípojka Connector 	Těsnění Sealing ring 
Ø41 ÷ Ø58	US 4511-T20	SDR T20	M12x1,5	JS 6	12x16

TYP/TYPE 7720.1

VRTÁKY S VYMĚNITELNÝMI BŘITOVÝMI DESTIČKAMI INDEXABLE INSERT DRILLS



Viz strana 43 / See page 43

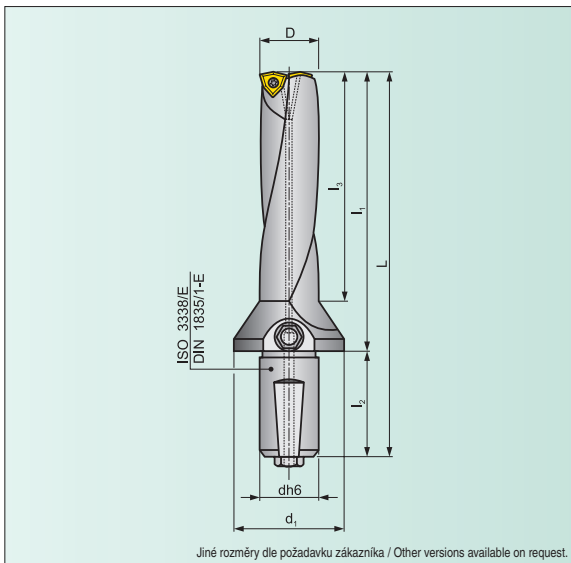

Jiné rozměry dle požadavku zákazníka / Other versions available on request.



● Doporučené použití / Recommended application

● Možné použití (více str.52) / Possible applications (see more on pg. 52)





○ Nedoporučuje se / Not recommended

D	h	Označení vrtáku Marking of drill	Sortiment/Assortment	Rozměry / Dimensions						Středová destička Centre insert	Obvodová destička Peripheral insert	Radiální nastavení Radial adjustment	
				L	L ₁	L ₂	L ₃	dh6	d ₁			WCMT	WCMT
41	143	7720.1-41	○	257	189	68	147	40	60	0804..	0804..	0,12	0,80
42	147	7720.1-42	●	257	189	68	147	40	60	0804..	0804..	0,12	0,75
43	150	7720.1-43	○	264	196	68	154	40	60	0804..	0804..	0,12	0,70
44	154	7720.1-44	●	264	196	68	154	40	60	0804..	0804..	0,15	0,65
45	157	7720.1-45	●	271	203	68	161	40	60	0804..	0804..	0,15	0,60
46	161	7720.1-46	○	271	203	68	161	40	60	0804..	0804..	0,15	0,55
47	164	7720.1-47	○	278	210	68	168	40	60	0804..	0804..	0,15	0,50
48	168	7720.1-48	○	278	210	68	168	40	60	0804..	0804..	0,15	0,40
49	171	7720.1-49	○	285	217	68	175	40	60	0804..	0804..	0,15	0,40
50	175	7720.1-50	●	285	217	68	175	40	60	0804..	0804..	0,15	0,35
51	178	7720.1-51	○	292	224	68	182	40	60	0804..	0804..	0,15	0,30
52	182	7720.1-52	○	292	224	68	182	40	60	0804..	0804..	0,15	0,30
53	185	7720.1-53	○	299	231	68	189	40	60	0804..	0804..	0,15	0,30
54	189	7720.1-54	○	299	231	68	189	40	60	0804..	0804..	0,15	0,25
55	192	7720.1-55	●	306	238	68	196	40	60	0804..	0804..	0,18	0,25
56	196	7720.1-56	○	306	238	68	196	40	60	0804..	0804..	0,18	0,20
57	199	7720.1-57	○	313	245	68	203	40	60	0804..	0804..	0,20	0,20
58	203	7720.1-58	●	313	245	68	203	40	60	0804..	0804..	0,20	0,20

● Skladovaný / Stock Assort. ○ Neskladovaný / Non-stock assort.

Všechny rozměry v [mm] / All dimensions [mm]

NÁHRADNÍ DÍLY / SPARE PARTS

Vrták Drill	Upínací šroub Clamping screw 	Šroubovák Screwdriver 	Zátka Plug 	Přípojka Connector 	Těsnění Sealing ring 
Ø41 ÷ Ø58	US 4511-T20	SDR T20	M12x1,5	JS 6	12x16

XPET AP

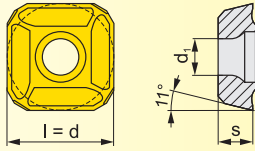

ISO	ANSI	Materiály / Grades				Rozměry / Dimensions				
		8040				l	d	s	d ₁	r _e
XPET 0502AP	XPET -(1.5)AP	●				5,556	5,556	2,38	2,40	-
XPET 0602AP	XPET -(1.5)AP	●				6,350	6,350	2,38	2,60	-
XPET 0703AP	XPET -2AP	●				7,937	7,937	3,18	2,90	-
XPET 0903AP	XPET -2AP	●				9,525	9,525	3,18	3,50	-
XPET 11T3AP	XPET -(2.5)AP	●				11,509	11,509	3,97	3,90	-
XPET 12T3AP	XPET -(2.5)AP	●				12,700	12,700	3,97	3,90	-
XPET 1504AP	XPET -3AP	●				15,875	15,875	4,76	4,50	-
XPET 1904AP	XPET -3AP	●				19,050	19,050	4,76	4,50	-

SCET-UD

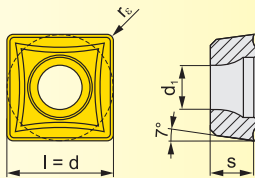

ISO	ANSI	Materiály / Grades				Rozměry / Dimensions				
		5030D	8030			l	d	s	d ₁	r _e
SCET 050204-UD	SCET -(1.5)1-UD	●	●			5,556	5,556	2,38	2,40	0,4
SCET 060204-UD	SCET -(1.5)1-UD	●	●			6,350	6,350	2,38	2,90	0,4
SCET 070308-UD	SCET -22-UD	●	●			7,937	7,937	3,18	3,50	0,8
SCET 09T308-UD	SCET 3(2.5)2-UD	●	●			9,525	9,525	3,97	4,50	0,8
SCET 120408-UD	SCET 432-UD	●	●			12,700	12,700	4,76	5,60	0,8
SCET 150512-UD	SCET 5(3.5)3-UD	●				15,875	15,875	5,56	5,60	1,2

● Skladovaný / Stock Assort. ○ Neskladovaný / Non-stock assort. Všechny rozměry v [mm] / All dimensions [mm]

WCMT E-45 / 46 / 47 / 48 / UM

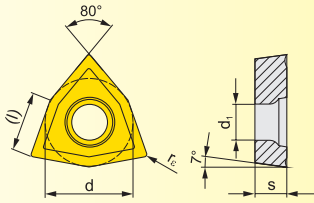

ISO	ANSI	Materiály / Grades				Rozměry / Dimensions				
		6640	8030			(l)	d	s	d ₁	r _c
WCMT 040208E-46	WCMT 2(1.5)2E-46	●	●			4,300	6,350	2,38	2,80	0,8
WCMT 040208E-UM	WCMT 2(1.5)2E-UM	●	●			4,300	6,350	2,38	2,80	0,8
WCMT 050308E-47	WCMT (2.5)22E-47	●	●			5,400	7,938	3,18	3,40	0,8
WCMT 050308E-UM	WCMT (2.5)22E-UM	●	●			5,400	7,938	3,18	3,40	0,8
WCMT 06T308E-45	WCMT 3(2.5)2E-45	●	●			6,500	9,525	3,97	4,40	0,8
WCMT 080412E-48	WCMT 433E-48	●	●			8,700	12,700	4,76	5,50	1,2

WCMX E-45 / 46 / 47 / 48 / UD

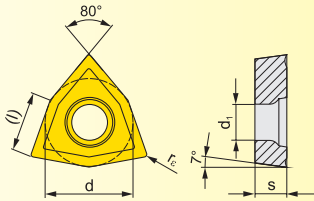

ISO	ANSI	Materiály / Grades				Rozměry / Dimensions				
		6640	8030			(l)	d	s	d ₁	r _c
WCMX 030208E-46	WCMX (1.5)(1.5)2E-46	●				3,800	5,556	2,38	2,85	0,8
WCMX 030208E-UD	WCMX (1.5)(1.5)2E-UD	●				3,800	5,556	2,38	2,60	0,8
WCMX 040208E-46	WCMX 2(1.5)2E-46	●				4,300	6,350	2,38	3,15	0,8
WCMX 040208E-UD	WCMX 2(1.5)2E-UD	●				4,300	6,350	2,38	2,90	0,8
WCMX 050308E-47	WCMX (2.5)22E-47	●				5,400	7,938	3,18	3,20	0,8
WCMX 050308E-UD	WCMX (2.5)22E-UD	●				5,400	7,938	3,18	3,50	0,8
WCMX 06T308E-45	WCMX 3(2.5)2E-45	●				6,500	9,525	3,97	3,72	0,8
WCMX 06T308E-UD	WCMX 3(2.5)2E-UD	●				6,500	9,525	3,97	3,90	0,8
WCMX 080412E-48	WCMX 433E-48	●				8,700	12,700	4,76	4,30	1,2
WCMX 080412E-UD	WCMX 433E-UD	●				8,700	12,700	4,76	4,50	1,2

● Skladovaný / Stock Assort. ○ Neskladovaný / Non-stock assort.

Všechny rozměry v [mm] / All dimensions [mm]

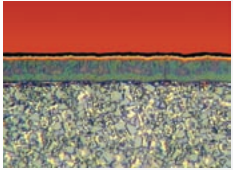
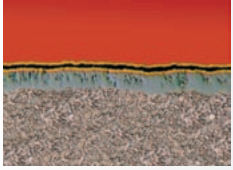
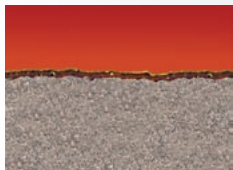
Označení materiálu a mikrostruktura Designation and microstructure	Aplikační oblasti Application area	Skupina obráběných materiálů Workpiece Material Group	Popis materiálu a doporučené užití Grade description and recommended application																																																																																																														
<p>5030D</p> 	<table border="1"> <tr> <th>10</th> <th>20</th> <th>30</th> <th>40</th> </tr> <tr> <td></td> <td></td> <td style="background-color: #00AEEF; color: white;">■</td> <td></td> </tr> <tr> <td></td> <td style="background-color: #FFD700;">■</td> <td></td> <td></td> </tr> <tr> <td></td> <td></td> <td style="background-color: #FF4500; color: white;">■</td> <td></td> </tr> <tr> <td></td> <td></td> <td></td> <td></td> </tr> <tr> <td></td> <td></td> <td></td> <td></td> </tr> <tr> <td></td> <td></td> <td></td> <td></td> </tr> <tr> <td></td> <td></td> <td></td> <td></td> </tr> <tr> <td></td> <td></td> <td></td> <td></td> </tr> <tr> <td></td> <td></td> <td></td> <td></td> </tr> </table>	10	20	30	40			■			■					■																										<table border="1"> <tr> <th>P</th> <th>M</th> <th>K</th> <th>N</th> <th>S</th> <th>H</th> </tr> <tr> <td style="background-color: #ADD8E6;">■</td> <td style="background-color: #FFFF00;">■</td> <td style="background-color: #FF4500;">■</td> <td style="background-color: #008000;">■</td> <td style="background-color: #A0522D;">■</td> <td style="background-color: #808080;">■</td> </tr> <tr> <td></td> <td style="border: 1px solid black;">□</td> <td></td> <td></td> <td></td> <td></td> </tr> <tr> <td></td> <td></td> <td style="background-color: #000000;">■</td> <td></td> <td></td> <td></td> </tr> <tr> <td></td> <td></td> <td></td> <td></td> <td></td> <td></td> </tr> <tr> <td></td> <td></td> <td></td> <td></td> <td></td> <td></td> </tr> <tr> <td></td> <td></td> <td></td> <td></td> <td></td> <td></td> </tr> <tr> <td></td> <td></td> <td></td> <td></td> <td></td> <td></td> </tr> <tr> <td></td> <td></td> <td></td> <td></td> <td></td> <td></td> </tr> <tr> <td></td> <td></td> <td></td> <td></td> <td></td> <td></td> </tr> <tr> <td></td> <td></td> <td></td> <td></td> <td></td> <td></td> </tr> </table>	P	M	K	N	S	H	■	■	■	■	■	■		□							■																																														<p>OBVODOVÉ DESTIČKY Materiál určený pro střední a vysoké řezné rychlosti. Pro operace s dobrými záběrovými podmínkami. Podmínkou použití je intenzivní výplach řeznou kapalinou. Materiál je vhodný pro obrábění běžných uhlíkových ocelí i slitinových ocelí a zejména pro litiny. Podmíněně lze tento materiál použít pro obrábění korozivzdorných a zušlechťených materiálů.</p> <p>PERIPHERAL INSERTS This grade is intended for medium and high cutting speeds. For operations with good engagement conditions. A condition is to use an intensive drilling fluid. This grade is suitable for machining of common carbon and alloy steels and especially cast irons. It can be conditionally used for machining of stainless and treated materials.</p>				
10	20	30	40																																																																																																														
		■																																																																																																															
	■																																																																																																																
		■																																																																																																															
P	M	K	N	S	H																																																																																																												
■	■	■	■	■	■																																																																																																												
	□																																																																																																																
		■																																																																																																															
<p>6640</p> 	<table border="1"> <tr> <th>10</th> <th>20</th> <th>30</th> <th>40</th> </tr> <tr> <td></td> <td></td> <td style="background-color: #00AEEF; color: white;">■</td> <td></td> </tr> <tr> <td></td> <td style="background-color: #FFD700;">■</td> <td></td> <td></td> </tr> <tr> <td></td> <td></td> <td style="background-color: #FF4500; color: white;">■</td> <td></td> </tr> <tr> <td></td> <td></td> <td></td> <td></td> </tr> <tr> <td></td> <td></td> <td></td> <td></td> </tr> <tr> <td></td> <td></td> <td></td> <td></td> </tr> <tr> <td></td> <td></td> <td></td> <td></td> </tr> <tr> <td></td> <td></td> <td></td> <td></td> </tr> <tr> <td></td> <td></td> <td></td> <td></td> </tr> <tr> <td></td> <td></td> <td></td> <td></td> </tr> </table>	10	20	30	40			■			■					■																														<table border="1"> <tr> <th>P</th> <th>M</th> <th>K</th> <th>N</th> <th>S</th> <th>H</th> </tr> <tr> <td style="background-color: #ADD8E6;">■</td> <td style="background-color: #FFFF00;">■</td> <td style="background-color: #FF4500;">■</td> <td style="background-color: #008000;">■</td> <td style="background-color: #A0522D;">■</td> <td style="background-color: #808080;">■</td> </tr> <tr> <td></td> <td style="border: 1px solid black;">□</td> <td></td> <td></td> <td></td> <td></td> </tr> <tr> <td></td> <td></td> <td style="background-color: #000000;">■</td> <td></td> <td></td> <td></td> </tr> <tr> <td></td> <td></td> <td></td> <td></td> <td></td> <td></td> </tr> <tr> <td></td> <td></td> <td></td> <td></td> <td></td> <td></td> </tr> <tr> <td></td> <td></td> <td></td> <td></td> <td></td> <td></td> </tr> <tr> <td></td> <td></td> <td></td> <td></td> <td></td> <td></td> </tr> <tr> <td></td> <td></td> <td></td> <td></td> <td></td> <td></td> </tr> <tr> <td></td> <td></td> <td></td> <td></td> <td></td> <td></td> </tr> <tr> <td></td> <td></td> <td></td> <td></td> <td></td> <td></td> </tr> </table>	P	M	K	N	S	H	■	■	■	■	■	■		□							■																																														<p>OBVODOVÉ DESTIČKY Nejhouževnatější materiál řady MT CVD. Je určen pro zhoršené záběrové podmínky při obrábění běžných i korozivzdorných ocelí a litin.</p> <p>PERIPHERAL INSERTS It is the toughest grade of the series MT CVD. It is intended for worse engagement conditions at machining of common and stainless steels and cast irons</p>
10	20	30	40																																																																																																														
		■																																																																																																															
	■																																																																																																																
		■																																																																																																															
P	M	K	N	S	H																																																																																																												
■	■	■	■	■	■																																																																																																												
	□																																																																																																																
		■																																																																																																															
<p>8030</p> 	<table border="1"> <tr> <th>10</th> <th>20</th> <th>30</th> <th>40</th> </tr> <tr> <td></td> <td></td> <td style="background-color: #00AEEF; color: white;">■</td> <td></td> </tr> <tr> <td></td> <td style="background-color: #FFD700;">■</td> <td></td> <td></td> </tr> <tr> <td></td> <td></td> <td style="background-color: #FF4500; color: white;">■</td> <td></td> </tr> <tr> <td></td> <td></td> <td></td> <td></td> </tr> <tr> <td></td> <td></td> <td></td> <td></td> </tr> <tr> <td></td> <td></td> <td></td> <td></td> </tr> <tr> <td></td> <td></td> <td></td> <td></td> </tr> <tr> <td></td> <td></td> <td></td> <td></td> </tr> <tr> <td></td> <td></td> <td></td> <td></td> </tr> <tr> <td></td> <td></td> <td></td> <td></td> </tr> </table>	10	20	30	40			■			■					■																														<table border="1"> <tr> <th>P</th> <th>M</th> <th>K</th> <th>N</th> <th>S</th> <th>H</th> </tr> <tr> <td style="background-color: #ADD8E6;">■</td> <td style="background-color: #FFFF00;">■</td> <td style="background-color: #FF4500;">■</td> <td style="background-color: #008000;">■</td> <td style="background-color: #A0522D;">■</td> <td style="background-color: #808080;">■</td> </tr> <tr> <td></td> <td></td> <td style="background-color: #000000;">■</td> <td></td> <td></td> <td></td> </tr> <tr> <td></td> <td></td> <td></td> <td></td> <td></td> <td></td> </tr> <tr> <td></td> <td></td> <td></td> <td></td> <td></td> <td></td> </tr> <tr> <td></td> <td></td> <td></td> <td></td> <td></td> <td></td> </tr> <tr> <td></td> <td></td> <td></td> <td></td> <td></td> <td></td> </tr> <tr> <td></td> <td></td> <td></td> <td></td> <td></td> <td></td> </tr> <tr> <td></td> <td></td> <td></td> <td></td> <td></td> <td></td> </tr> <tr> <td></td> <td></td> <td></td> <td></td> <td></td> <td></td> </tr> <tr> <td></td> <td></td> <td></td> <td></td> <td></td> <td></td> </tr> </table>	P	M	K	N	S	H	■	■	■	■	■	■			■																																																				<p>OBVODOVÉ / VNITŘNÍ DESTIČKY Materiál určený pro střední řezné rychlosti. Pro operace s méně stabilními záběrovými podmínkami. Používá se především pro obrábění běžných i korozivzdorných ocelí. Lze ho dále použít pro obrábění litin i superslitin. Materiál vykazuje velkou provozní spolehlivost.</p> <p>PERIPHERAL / INTERNAL INSERTS It is intended for medium cutting speeds. For operations with less stable engagement conditions. Before all it is used for machining of common and stainless steels. It can be also used for machining of cast irons and superalloys. The grade shows a high operation reliability.</p>
10	20	30	40																																																																																																														
		■																																																																																																															
	■																																																																																																																
		■																																																																																																															
P	M	K	N	S	H																																																																																																												
■	■	■	■	■	■																																																																																																												
		■																																																																																																															

■ - hlavní oblast použití / main application ■ - další použití / other application □ - podmíněné použití / conditional application

Označení materiálu a mikrostruktura Designation and microstructure	Aplikační oblasti Application area	Skupina obráběných materiálů Workpiece Material Group	Popis materiálu a doporučené užití Grade description and recommended application
---	---------------------------------------	--	---

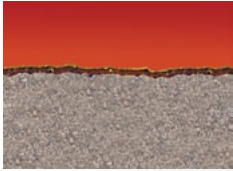
<p>8040</p> 	10	20	30	40	P	M	K	N	S	H	<p>VNITŘNÍ DESTIČKY Jedná se o nejhůževnatější materiál, který je určen pro extrémní namáhání a špatné záběrové podmínky. Své uplatnění nachází především při obrábění ocelí i korozivzdorných a litin při zhoršených podmínkách. Je vhodný pro obrábění těžkoobrobitelných slitin.</p> <p>INTERNAL INSERTS It is the toughest grade intended for extremely loading and bad engagement conditions. It finds its application before all for machining of steels and stainless steels at worse conditions. It is also suitable for machining of badly machinable alloys .</p>

■ - hlavní oblast použití / main application

■ - další použití / other application

□ - podmíněné použití / conditional application

EP

**NASTAVITELNÉ POUZDRO
ADJUSTABLE SLEEVE**



* Pouze pro vrtáky 802D a 803D / For drills 802D and 803D only.

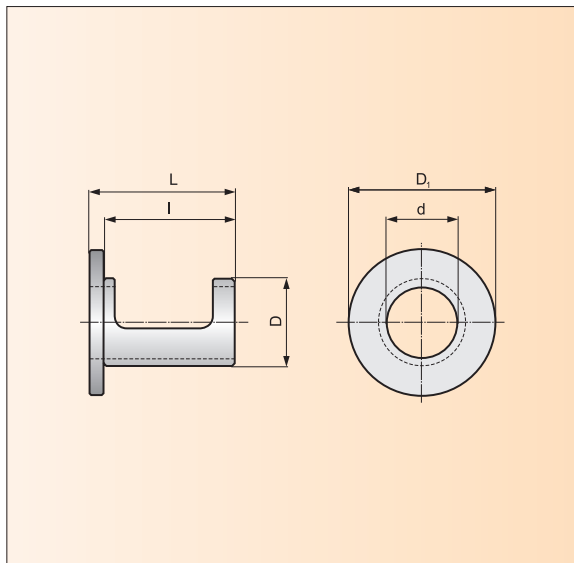

Označení pouzdra Sleeve marking	Sortiment / Assortment	Rozměry / Dimensions						Rozsah nastavení průměru Dia adjustment range	Rozsah nastavení výšky středu Center height adjustment range	[kg]
		d	D	D ₁	L	l				
EP253253 *	●	25	32	53	53	48	+ 0,4 ÷ - 0,2	+ 0,2 ÷ - 0,15	0,15	
EP324058 *	●	32	40	58	58	53	+ 0,4 ÷ - 0,2	+ 0,2 ÷ - 0,15	0,17	

● Skladovaný / Stock Assort. ○ Neskladovaný / Non-stock assort. Všechny rozměry v [mm] / All dimensions [mm]

OBSAH CONTENT
 MONOLITNÍ VRTÁKY SOLID DRILLS
 DESTIČKOVÉ VRTÁKY INDEXABLE DRILLS
 VYMĚNITELNÉ DESTIČKY INDEXABLE INSERTS
 NASTAVITELNÉ POUZDRO ADJUSTABLE SLEEVE
 ŘEZNÉ PODMÍNKY CUTTING CONDITIONS
 TECHNICKÁ ČÁST TECHNICAL PART

NASTAVENÍ PRŮMĚRU PRO OBRÁBĚCÍ CENTRA / DIAMETER ADJUSTMENT - FOR MACHINING CENTER

Rozsah nastavení průměru / Diameter adjustment range

Průměr stopy Shank dia	Průměr vrtáku Drill dia	Rozsah Range
25	15 – 24	+ 0,4 ÷ - 0,2
32	24,5 – 40	+ 0,4 ÷ - 0,2

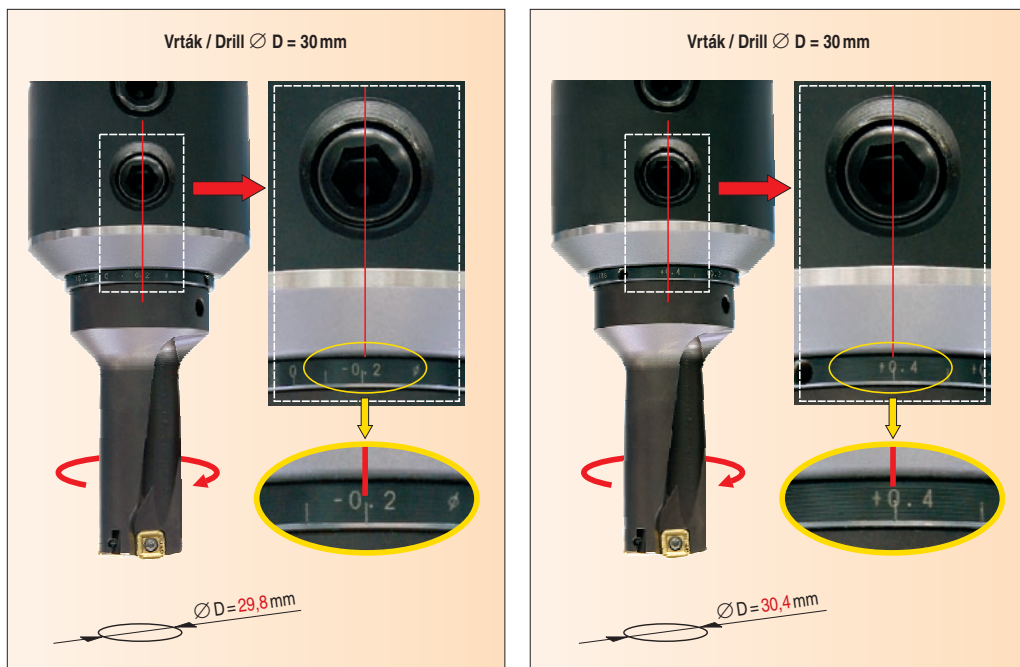
NASTAVENÍ VÝŠKY STŘEDU - PRO SOUSTRUŽNICKÉ OPERACE / CENTER HEIGHT ADJUSTMENT - FOR LATHE OPERATION
Rozsah nastavení výšky středu / Center height adjustment range

Průměr stopy Shank dia	Průměr vrtáku Drill dia	Rozsah Range
25	15 – 24	+ 0,2 ÷ - 0,15
32	24,5 – 40	+ 0,2 ÷ - 0,15

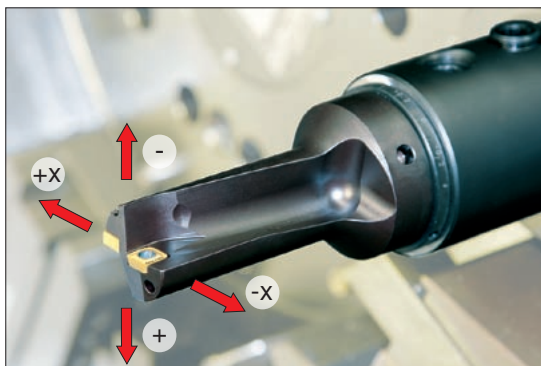

● Skladovaný / Stock Assort.

○ Neskladovaný / Non-stock assort.

Všechny rozměry v [mm] / All dimensions [mm]

DOPORUČENÉ ŘEZNÉ PODMÍNKY PRO MONOLITNÍ VRTÁKY
RECOMMENDED CUTTING CONDITIONS FOR SOLID DRILLS

303DS / 301CS

Skupina materiálů Material group	Doporučená řezná rychlost v_c [m/min] Recommended cutting speed v_c [m/min]	Doporučený posuv f [mm/ot.] pro průměr vrtáků Recommended feed f [mm/rev.] for drill diameter							
		∅ 3	∅ 4	∅ 6	∅ 8	∅ 10	∅ 12	∅ 16	∅ 20
P_I	80 ÷ 120	0,08	0,11	0,16	0,18	0,22	0,28	0,34	0,40
P_{II}	70 ÷ 105	0,08	0,11	0,16	0,18	0,22	0,28	0,34	0,40
P_{III}	50 ÷ 70	0,07	0,10	0,14	0,18	0,20	0,22	0,25	0,30
P_{IV}	35 ÷ 50	0,05	0,06	0,08	0,10	0,14	0,16	0,18	0,20
M	-	-	-	-	-	-	-	-	-
K	50 ÷ 110	0,09	0,12	0,16	0,22	0,26	0,30	0,35	0,40
N	-	-	-	-	-	-	-	-	-
S	-	-	-	-	-	-	-	-	-
H	-	-	-	-	-	-	-	-	-

303DA / 305DA / 303TA

Skupina materiálů Material group	Doporučená řezná rychlost v_c [m/min] Recommended cutting speed v_c [m/min]	Doporučený posuv f [mm/ot.] pro průměr vrtáků Recommended feed f [mm/rev.] for drill diameter							
		∅ 3	∅ 4	∅ 6	∅ 8	∅ 10	∅ 12	∅ 16	∅ 20
P_I	80 ÷ 150	0,10	0,13	0,18	0,24	0,27	0,30	0,36	0,42
P_{II}	70 ÷ 120	0,12	0,15	0,20	0,24	0,27	0,30	0,36	0,45
P_{III}	60 ÷ 80	0,10	0,12	0,15	0,20	0,22	0,25	0,28	0,35
P_{IV}	40 ÷ 65	0,06	0,08	0,10	0,13	0,16	0,16	0,20	0,25
M	-	-	-	-	-	-	-	-	-
K	50 ÷ 130	0,10	0,15	0,18	0,25	0,30	0,35	0,40	0,50
N	-	-	-	-	-	-	-	-	-
S	-	-	-	-	-	-	-	-	-
H	-	-	-	-	-	-	-	-	-

Skupiny obráběných materiálů viz strana 59 / Groups of machined materials see page 59.

DOPORUČENÉ ŘEZNÉ PODMÍNKY PRO MONOLITNÍ VRTÁKY
RECOMMENDED CUTTING CONDITIONS FOR SOLID DRILLS

308FA									
Skupina materiálů Material group	Doporučená řezná rychlost v_c [m/min] Recommended cutting speed v_c [m/min]	Doporučený posuv f [mm/ot.] pro průměr vrtáku Recommended feed f [mm/rev.] for drill diameter							
		∅ 3	∅ 4	∅ 6	∅ 8	∅ 10	∅ 12	∅ 16	∅ 20
P_I	80 ÷ 150	0,08	0,10	0,14	0,19	0,22	0,24	0,29	0,34
P_{II}	70 ÷ 120	0,10	0,12	0,16	0,19	0,22	0,24	0,29	0,36
P_{III}	60 ÷ 80	0,08	0,10	0,12	0,16	0,18	0,20	0,22	0,28
P_{IV}	40 ÷ 65	0,05	0,06	0,08	0,10	0,13	0,13	0,16	0,20
M	-	-	-	-	-	-	-	-	-
K	50 ÷ 130	0,08	0,12	0,14	0,20	0,24	0,28	0,32	0,40
N	-	-	-	-	-	-	-	-	-
S	-	-	-	-	-	-	-	-	-
H	-	-	-	-	-	-	-	-	-

Skupiny obráběných materiálů viz strana 59/Groups of machined materials see page 59.

DOPORUČENÉ ŘEZNÉ PODMÍNKY PRO DESTIČKOVÉ VRTÁKY
RECOMMENDED CUTTING CONDITIONS FOR INDEXABLE DRILLS

802D / 803D

Skupina materiálů Recommended geometry, grade and cutting speed v_c [m/min]	Doporučená geometrie, materiál a řezná rychlost v_c [m/min] Recommended geometry, grade and cutting speed v_c [m/min]			Doporučený posuv f [mm/ot.] pro průměr vrtáků Recommended feed f [mm/rev.] for drill diameter							
	Material group	v_c [m/min]	Obvodová VBD Peripheral inserts Materiál / Grade	Středová VBD Centre inserts Materiál / Grade	∅ 15	∅ 20	∅ 25	∅ 30	∅ 40	∅ 58	
P_I	250 ÷ 300	SCET	5030D 8030	XPET	8040	0,05	0,06	0,07	0,08	0,09	0,10
P_{II}	230 ÷ 270		5030D 8030		8040	0,10	0,12	0,14	0,16	0,18	0,20
P_{III}	180 ÷ 230		5030D 8030		8040	0,11	0,15	0,18	0,20	0,22	0,24
P_{IV}	100 ÷ 180		5030D 8030		8040	0,10	0,15	0,18	0,20	0,22	0,24
M	120 ÷ 200		8030		8040	0,07	0,09	0,11	0,12	0,13	0,14
K	150 ÷ 240		8030 5030D		8040	0,15	0,16	0,18	0,20	0,23	0,26
N	-		-		-	-	-	-	-	-	-
S	80 ÷ 120		8030		8040	0,07	0,09	0,10	0,11	0,12	0,13
H	-	-	-	-	-	-	-	-	-		

804D

Skupina materiálů Recommended geometry, grade and cutting speed v_c [m/min]	Doporučená geometrie, materiál a řezná rychlost v_c [m/min] Recommended geometry, grade and cutting speed v_c [m/min]			Doporučený posuv f [mm/ot.] pro průměr vrtáků Recommended feed f [mm/rev.] for drill diameter						
	Material group	v_c [m/min]	Obvodová VBD Peripheral inserts Materiál / Grade	Středová VBD Centre inserts Materiál / Grade	∅ 17	∅ 20	∅ 25	∅ 30	∅ 40	
P_I	210 ÷ 280	SCET	5030D 8030	XPET	8040	0,05	0,06	0,07	0,08	0,09
P_{II}	180 ÷ 240		5030D 8030		8040	0,08	0,09	0,11	0,13	0,14
P_{III}	140 ÷ 210		5030D 8030		8040	0,08	0,09	0,11	0,13	0,14
P_{IV}	90 ÷ 160		5030D 8030		8040	0,08	0,09	0,11	0,13	0,14
M	100 ÷ 160		8030		8040	0,07	0,08	0,09	0,10	0,11
K	150 ÷ 240		8030 5030D		8040	0,11	0,13	0,14	0,17	0,18
N	-		-		-	-	-	-	-	-
S	70 ÷ 110		8030		8040	0,06	0,07	0,08	0,09	0,10
H	-	-	-	-	-	-	-	-		

Skupiny obráběných materiálů viz strana 59 / Groups of machined materials see page 59.

DOPORUČENÉ ŘEZNÉ PODMÍNKY PRO DESTIČKOVÉ VRTÁKY
RECOMMENDED CUTTING CONDITIONS FOR INDEXABLE DRILLS

805D								
Skupina materiálů	Doporučená geometrie, materiál a řezná rychlost v_c [m/min] Recommended geometry, grade and cutting speed v_c [m/min]			Doporučený posuv f [mm/ot.] pro průměr vrtáků Recommended feed f [mm/rev.] for drill diameter				
Material group	v_c [m/min]	Obvodová VBD Peripheral inserts Materiál / Grade	Středová VBD Centre inserts Materiál / Grade	∅ 19	∅ 20	∅ 25	∅ 31	
P_I	170 ÷ 240	SCET	XPET	8040	0,06	0,06	0,07	0,08
P_{II}	140 ÷ 210			8040	0,09	0,09	0,10	0,12
P_{III}	130 ÷ 200			8040	0,09	0,09	0,11	0,12
P_{IV}	90 ÷ 150			8040	0,09	0,09	0,11	0,12
M	90 ÷ 150			8040	0,08	0,08	0,09	0,10
K	150 ÷ 240			8040	0,13	0,13	0,14	0,17
N	-			-	-	-	-	-
S	60 ÷ 100			8040	0,07	0,07	0,08	0,09
H	-	-	-	-	-	-		

7720 / 7720.1						
Skupina materiálů	Doporučená geometrie, materiál a řezná rychlost v_c [m/min] Recommended geometry, grade and cutting speed v_c [m/min]			Doporučený posuv f [mm/ot.] pro průměr vrtáků Recommended feed f [mm/rev.] for drill diameter		
Material group	v_c [m/min]	Obvodová VBD Peripheral inserts Materiál / Grade	Středová VBD Centre inserts Materiál / Grade	∅ 41 ÷ 50	∅ 51 ÷ 58	
P_I	220 ÷ 250	WCMT	WCMT	0,10 ÷ 0,14	0,12 ÷ 0,18	
P_{II}	180 ÷ 210			0,12 ÷ 0,16	0,12 ÷ 0,18	
P_{III}	170 ÷ 190			0,12 ÷ 0,18	0,13 ÷ 0,20	
P_{IV}	140 ÷ 170			0,12 ÷ 0,18	0,13 ÷ 0,20	
M	120 ÷ 140			0,10 ÷ 0,18	0,11 ÷ 0,20	
K	150 ÷ 175			0,15 ÷ 0,22	0,18 ÷ 0,25	
N	-			-	-	
S	30 ÷ 50			0,09 ÷ 0,12	0,09 ÷ 0,14	
H	-	-	-			

Skupiny obráběných materiálů viz strana 59 / Groups of machined materials see page 59.

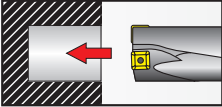
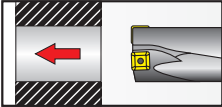
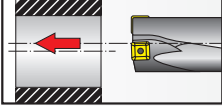
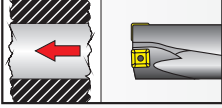
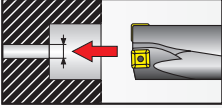
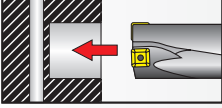
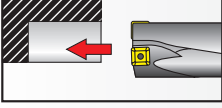
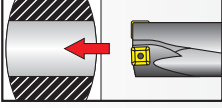
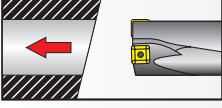
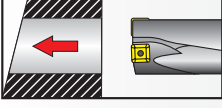
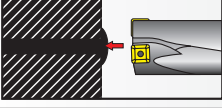
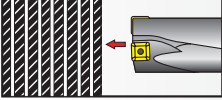
	<p>VRTÁNÍ SLEPÉ DÍRY Nepoužívejte srážče hran.</p>	<p>BLIND HOLE DRILLING Do not use chamfer drills.</p>
	<p>VRTÁNÍ PRŮCHOZÍ DÍRY Nepoužívejte srážče hran. Při vrtání destičkovými vrtáky může při vstupu vzniknout kroužek. V případě rotujícího obrobku může být tento kroužek vyhozen vysokou rychlostí. Ujistěte se, že je stroj zajištěn z hlediska bezpečnosti obsluhy.</p>	<p>THROUGH HOLE DRILLING Do not use chamfer drills. The disc can be produced when indexable drills exits material. This disc can be ejected at high speed when workpiece is rotating. It is the most important to ensure that the machine is guarded to ensure an operator safety.</p>
	<p>VRTÁNÍ MIMO OSU U destičkových vrtáků snižte posuv. Nepřekračujte hodnoty radiálního nastavení. Monolitní vrtáky nesmí být vysoeny více než 0,02 mm.</p>	<p>OFF-CENTER DRILLING Decrease the feed for indexable drills. Do not exceed radial adjustment values. Solid drills must not be out of center more than 0.02 mm.</p>
	<p>VRTÁNÍ DO NEPRÁVĚLNÉHO A LITÉHO PLOCHU Při vstupu destičkového vrtáku snižte posuv, dokud nejsou obě destičky v záběru. Před vrtáním monolitním vrtákem povrch zarovnejte monolitním frézou.</p>	<p>STARTING ON UNEVEN AND CAST SURFACES Decrease the feed on entrance for indexable drills until both inserts are engaged. Starting surface must be faced before using a solid drill.</p>
	<p>VYVRTÁVÁNÍ A VRTÁNÍ DO PŘEDVRTANÉ DÍRY Je-li stávající otvor větší než 1/4 průměru vrtáku, snižte posuv. Monolitní vrtáky nepoužívejte, hrozí vylovení špičky.</p>	<p>BORING AND DRILLING INTO CENTER DRILLED HOLE If a pre-drilled hole is larger than 1/4 drill diameter, decrease the feed. Do not use solid drills due to danger of a drill point damage.</p>
	<p>VRTÁNÍ NAPŘÍČ STÁVAJÍCÍCH OTVORŮ Při vrtání v oblasti protínající díry snižte posuv. Monolitní vrtáky je možné použít pouze pokud osa vrtáku protíná kolmo osu předvrtané díry.</p>	<p>DRILLING ACROSS AN EXISTING HOLE Decrease the feed when drill across an existing hole. Solid drills can be used only when the axis of the drill crosses the axis of pre-drilled hole perpendicularly.</p>
	<p>PŘERUŠOVANÝ ŘEZ A PONORNÉ VRTÁNÍ Při vrtání destičkovými vrtáky snižte posuv. Monolitní vrtáky nelze použít.</p>	<p>INTERRUPTED CUT AND PLUNGING Decrease the feed for indexable drills. Do not use solid drills.</p>
	<p>VRTÁNÍ DO ZAKŘIVĚNÉHO PLOCHU Jestliže osa vrtáku směřuje do středu zaoblení, snižte posuv. Je-li osa vrtání mimo střed zaoblení, nelze použít monolitní vrták bez předchozího zarovnání povrchu monolitním frézou.</p>	<p>DRILLING ON CURVED SURFACE Centered drilling can be started with reduced feed rate. Spot facing is required for solid drills when the point for starting the hole is outside the radius center.</p>
	<p>ŠIKMÝ VSTUP DO MATERIÁLU Jestliže se vstupní plocha odchyluje o více než 5°, snižte u destičkových vrtáků posuv, dokud nejsou obě destičky v záběru. Před vrtáním monolitním vrtákem zarovnejte povrch monolitním frézou tak, aby byl kolmý na osu vrtání.</p>	<p>STARTING ON ANGLED SURFACE Decrease the feed on entrance for indexable drills until both inserts are engaged if angle of entrance is more than 5°. Starting surface must be faced perpendicularly before using a solid drill.</p>
	<p>ÚHEL NA VÝSTUPU Z MATERIÁLU Jestliže se výstupní plocha odchyluje o více než 5°, snižte při výjezdu posuv.</p>	<p>ANGLED BORE EXIT Decrease the feed on exit if angle of exit is more than 5°.</p>
	<p>VRTÁNÍ PŘES SVAR Před zahájením vrtání rovnejte plochu. Při průchodu svarem snižte posuv.</p>	<p>STARTING ON A WELDED SEAM Facing is recommended before the start of drilling. Decrease the feed until drilling welded material.</p>
	<p>VRTÁNÍ NASKLÁDANÝCH MATERIÁLŮ Naskládané materiály upněte pevně a tak, aby mezi nimi nebyly mezery větší než 0,2 mm. Je-li to nutné, snižte posuv. Nelze použít trigonové vrtáky typu 7720 a 7720.1</p>	<p>DRILLING OF STACKED MATERIALS Avoid spaces larger 0.2mm between elements. The component must be securely fixed. If necessary reduce the feed. Do not use trigon drills type 7720 or 7720.1</p>

CHLAZENÍ

Přívod chladicí kapaliny vrtákem zlepší odvod třísek, mazání nástroje a chlazení.

COOLING

Coolant supply through the drill will improve chip evacuation, lubrication of the tool and cooling.

Hloubka vrtání Drilling depth	Minimální doporučený tlak Minimal recommended pressure
< 3D	10 bar
> 3D	20 bar
> 5D	40 bar

Doporučená koncentrace emulze je 6 – 8 %

Vnější přívod chladicí kapaliny se doporučuje pouze tehdy, jestliže hloubka vrtání nepřesáhne 2,5 × D.

Recommended emulsion mix is 6 – 8 %

External coolant supply is only recommended when drilling depth is maximum 2.5 × D.

UPNUTÍ A HÁZENÍ

Vrtáky s válcovými stopkami mohou být upnuty kleštinovým sklíčidlem, hydraulickým sklíčidlem nebo tepelným upínačem. Pro nejlepší výsledky dodržte házení < 0,02 mm.

HOLDING AND RUN-OUT

Drills with cylindrical shanks can be used with Shrinkfit holders, hydraulic chucks or collet chucks. For best result keep run-out < 0.02 mm.

TUHOST

Tuhost upnutí je důležitá pro dosažení nejlepší životnosti nástroje a přesnosti díry. Zkontrolujte stav vřetena stroje, upínače a upevnění obrobku, abyste zajistili maximální stabilitu a tuhost. Nestabilní podmínky můžou způsobit zlomení nástroje.

STABILITY

The stability of the application is important to obtain the best tool life and hole accuracy. Check the condition of the machine spindle, fixture and fixturing of the component to secure maximum stability and rigidity. Unstable conditions can cause tool breakages.

ŽIVOTNOST

Vrtáky by neměly být používány s opotřebením hlavního ostří větším než 0,1 - 0,3 mm měřeno v nejširším bodě.

TOOL LIFE

Drills should not be used with flank wear exceeding 0.1 – 0.3 mm measured at the largest point.

RADIÁLNÍ NASTAVENÍ

Nastavení průměru otvoru a doporučení pro nastavení

Vrtáky s vyměnitelnými destičkami mohou být posunuty mimo střed, aby se docílil menší nebo větší průměr než má skutečný vrták. Hodnoty „Radiálního nastavení“ jsou uvedeny u hlavních rozměrů vrtáků.

Rotující nástroj

Pro přesné nastavení průměru otvoru IT10 se doporučuje nastavitelný upínač při použití nastavitelných vrtáků řady 80xD.

Stacionární nástroj

Při montáži vrtáku se ujistěte, že osa vrtáku je shodná s osou obrobku. Pro dosažení většího průměru otvoru přestavte vrták tak, aby se obvodová destička posunula směrem od osy obrobku.

RADIAL ADJUSTMENT

Hole diameter adjustment and set-up recommendation

The insert drills can be displaced off-centre to achieve a smaller or larger hole diameter than the actual drill. Radial adjustment values are introduced in the main drill data table.

Rotating tool

Adjustable holder is recommended for precision hole diameter IT10 setting when using line 80xD as rotating drills.

Stationary tool

When mounting the drill make sure the drill centre line and workpiece centre line are aline. To achieve a larger hole diameter, displace the drill so that the periphery insert moves in direction from the workpiece centre line.

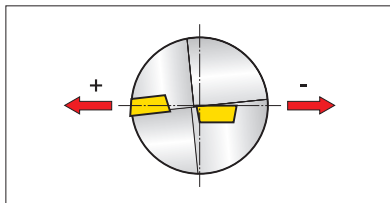

ŽIVOTNOST NÁSTROJE

Destičky by se neměly používat při opotřebení hřbetu větším než 0,2 ÷ 0,4 mm, měřeno v místě největšího opotřebení.

Doporučené řezné rychlosti, které jsou uvedeny v tomto katalogu, odpovídají životnosti obvodové destičky při vrtání otvoru celkové délky 7 m (20 ÷ 30 min.)

TOOL LIFE

Inserts should not be used with flank wear exceeding 0.2 ÷ 0.4 mm measured at the largest point.

Cutting speed recommendations mentioned in this catalogue are based upon peripheral insert tool life of total length drilled hole 7 m (durability 20 ÷ 30 min.)

DOPORUČENÝ TLAK PŘIVÁDĚNÉ ŘEZNÉ KAPALINY / RECOMMENDED PRESSURE OF SUPPLIED CUTTING FLUID

Průměr vrtáku / Drill diameter D [mm]	Tlak řezné kapaliny p / Pressure of cutting fluid p	
	Délka vrtáku / Drill length	
	2,0 ÷ 2,5 D	3,0 ÷ 5,0 D
15 ÷ 25	6 bar	12 bar
26 ÷ 40	4,5 bar	9 bar
> 40	3 bar	6 bar

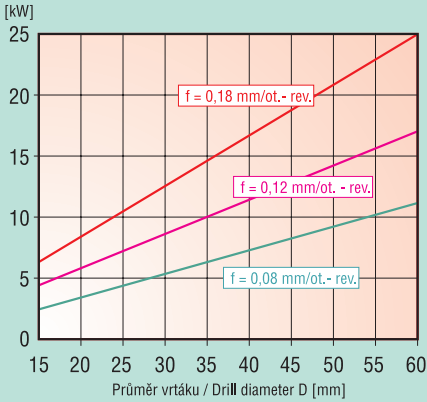

PŘÍKON
NET POWER CONSUMPTION

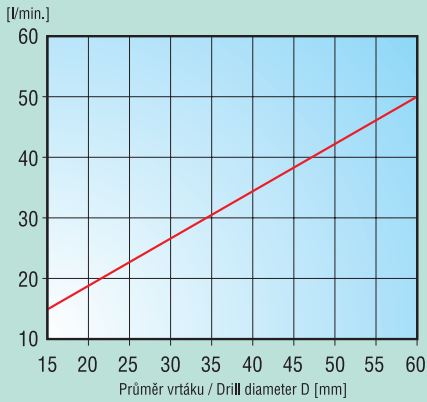

SPOTŘEBA CHLADÍČÍ KAPALINY
COOLANT VOLUME REQUIREMENT

VRTÁNÍ ZA SUCHA

Bez chladicího prostředku (řezné kapaliny) lze vrtat litinu a ocel; je zapotřebí průchod tlakového vzduchu.

DRY DRILLING

It is possible to drill without coolant in cast iron and steel, pressurised air through the drill is required.

RYCHLÉ OPOTŘEBENÍ BŘITU NEBO OBVODOVÉ FAZETKY	RAPID FLANK WEAR OR PERIPHERY LAND
<ul style="list-style-type: none"> a) snižte řeznou rychlost b) zvýšte koncentraci chladicí kapaliny 	<ul style="list-style-type: none"> a) reduce the cutting speed b) increase coolant concentration
VYLAMOVÁNÍ PŘÍČNÉHO OSTŘÍ	CHIPPING ON CENTER
<ul style="list-style-type: none"> a) během vnikání vrtáku snižte posuv b) zvýšte tlak chladicí kapaliny a seřídte posuv pro optimalizaci tvoření třísek 	<ul style="list-style-type: none"> a) reduce feed during entrance b) increase coolant pressure and adjust the feed to optimize the chip formation
VYLAMOVÁNÍ BŘITU NEBO VNĚJŠÍHO ROHU	CHIPPING ON OUTER CORNER OR CUTTING EDGE
<ul style="list-style-type: none"> a) během vnikání / výstupu vrtáku snižte posuv b) snižte řeznou rychlost c) zvýšte koncentraci chladicí kapaliny 	<ul style="list-style-type: none"> a) reduce feed during entrance / exit b) reduce the cutting speed c) increase coolant concentration
NÁRŮSTKY NA BŘITU	BUILT-UP EDGE
<ul style="list-style-type: none"> a) jsou-li blíže obvodu, zvýšte řeznou rychlost b) jsou-li blíže ke středu, zvýšte posuv 	<ul style="list-style-type: none"> a) if closer to periphery increase the cutting speed b) if closer to centre increase feed
NEVYHOVUJÍCÍ TOLERANCE PRŮMĚRU	UNSATISFACTORY DIAMETER TOLERANCE
<ul style="list-style-type: none"> a) zvýšte posuv 	<ul style="list-style-type: none"> a) increase the feed
NEVYHOVUJÍCÍ POLOHA OTVORU	UNSATISFACTORY POSITIONING OF THE HOLE
<ul style="list-style-type: none"> a) během vnikání vrtáku snižte posuv b) předvrtajte krátkým vrtákem 	<ul style="list-style-type: none"> a) reduce feed on entrance b) pre-drill with short drill
NEUSPOKOJIVÁ JAKOST POVRCHU	UNSATISFACTORY SURFACE FINISH
<ul style="list-style-type: none"> a) snižte posuv b) zvýšte řeznou rychlost 	<ul style="list-style-type: none"> a) reduce the feed b) increase the cutting speed
ZLOMENÍ VRTÁKU PŘI KONTAKTU NEBO KONCI OTVORU	BREAKAGE ON CONTACT OR AT HOLE BOTTOM
<ul style="list-style-type: none"> a) během vnikání / výstupu vrtáku snižte posuv b) nastavte řezné podmínky pro zlepšení odvodu třísek 	<ul style="list-style-type: none"> a) reduce the feed during entrance / exit b) adjust cutting data for improved chip evacuation

NÍZKÝ VÝKON HNACÍHO MOTORU (NÍZKÝ KROUČÍCÍ MOMENT NA VŘETENU)	LOW PERFORMANCE OF DRIVING MOTOR (LOW TWISTING MOMENT AT SPINDLE)
<ul style="list-style-type: none"> a) snížení řezné rychlosti - snížení otáček vřetene b) snížení posuvu 	<ul style="list-style-type: none"> a) reduction of cutting speed – reduction of spindle revolutions b) reduction of the feed
NADMĚRNÉ OPOTŘEBENÍ BŘITU OBVODOVÉ VBD	EXCESSIVE WEAR OF EDGE OF PERIPHERAL CUTTING INSERT
<ul style="list-style-type: none"> a) snížení řezné rychlosti b) volba otěruvzdornějšího druhu materiálu VBD c) zvýšení objemu a tlaku řezné kapaliny 	<ul style="list-style-type: none"> a) reduction of cutting speed – reduction of spindle revolutions b) choice of more wear-resistant insert grade c) increase of the cutting liquid volume and pressure
KŘEHKÉ PORUŠENÍ ŘEZNÉ HRANY OBVODOVÉ VBD	CHIPPING OF PERIPHERY INSERT
<ul style="list-style-type: none"> a) snížení posuvu při zavrtávání (zejména u nerovného vstupního povrchu obrobku) b) volba houževnatějšího druhu materiálu VBD c) snížení řezné rychlosti 	<ul style="list-style-type: none"> a) reduction of feed during drilling (especially at uneven entry surface of workpiece) b) choice of a tougher insert grade c) reduction of cutting speed
KŘEHKÉ PORUŠENÍ ŘEZNÉ HRANY VNITŘNÍ VBD	CHIPPING OF CENTRE INSERT
<ul style="list-style-type: none"> a) snížení posuvu při zavrtávání b) přezkontrolovat upnutí vrtáku a obrobku 	<ul style="list-style-type: none"> a) reduction of feed during entering b) check the drill and work piece clamping
PLYNULÁ, ŠPATNĚ UTVÁŘENÁ TŘÍSKA	CONTINUOUS, BADLY FORMED CHIP
<ul style="list-style-type: none"> a) změna posuvu b) zvýšit řeznou rychlost při současném snížení posuvu 	<ul style="list-style-type: none"> a) change of the feed b) increase of the cutting speed and simultaneously reduction of the feed
PĚCHOVÁNÍ KRÁTKÝCH TŘÍSEK V DRÁŽKÁCH PRO OBVOD	CROWDING OF SHORT CHIPS IN THE PERIPHERY GROOVES
<ul style="list-style-type: none"> a) zvýšení objemu a tlaku řezné kapaliny b) snížení řezné rychlosti c) změna posuvu 	<ul style="list-style-type: none"> a) increase of the cutting liquid volume and pressure b) reduction of the cutting speed c) change of the feed

OZNAČENÍ A VZORCE / NOMENCLATURE AND FORMULAE

Parametr Parameter	Vzorec Formulae	Jednotky Unit
Otáčky RPM	$n = \frac{v_c \cdot 1000}{D \cdot \pi}$	[ot.min ⁻¹] [rev.min ⁻¹]
Řezná rychlost Cutting speed	$v_c = \frac{\pi \cdot D \cdot n}{1000}$	[m.min ⁻¹]
Rychlost posuvu Table feed	$v_f = n \cdot f$	[mm.min ⁻¹]
Plocha příčného průřezu otvoru Cross section area of the hole	$A = \frac{\pi \cdot D^2}{4}$	[mm ²]
Objem odebíraného materiálu Metal removal rate	$Q = \frac{v_f \cdot A}{1000}$	[cm ³ .min ⁻¹]
Doba obrábění Machining time	$T_c = \frac{L + h}{v_f}$	[min / kus] [min / pc]
<p>D Průměr vrtáku [mm]</p> <p>f Posuv na otáčku [mm.ot⁻¹]</p> <p>h Bezpečná vzdálenost nájezdu špičky vrtáku od obrobku [mm]</p> <p>L Hloubka díry [mm]</p>	<p>D Diameter of drill [mm]</p> <p>f Feed per revolution [mm.rev⁻¹]</p> <p>h Distance from drill point to workpiece before feeding [mm]</p> <p>L Depth of hole [mm]</p>	

OBSAH
 CONTENT

MONOLITNI VRTÁKY
 SOLID DRILLS

DESTIČKOVÉ VRTÁKY
 INDEXABLE DRILLS

VYMĚNITELNÉ DESTIČKY
 INDEXABLE INSERTS

NASTAVITELNÉ POUZDRO
 ADJUSTABLE SLEEVE

ŘEZNÉ PODMÍNKY
 CUTTING CONDITIONS

TECHNICKÁ ČÁST
 TECHNICAL PART

P	P_I <450 [N/mm ²]	Měkké oceli s nízkým obsahem uhlíku. Feritické oceli.	Very soft low-carbon steels. Ferritic steels.
	P_{II} 400÷700 [N/mm ²]	Dobře obrobitelné oceli. Konstrukční uhlíkové oceli s obsahem uhlíku <0,5%.	Well machinable steels. Structural steels with carbon content < 0,5 %.
	P_{III} 550÷900 [N/mm ²]	Konstrukční uhlíkové oceli s obsahem uhlíku <0,5%, středně tvrdé oceli k zušlechťení. Litě konstrukční oceli. Běžné nástrojové oceli, i tvrdší oceli pro zušlechťení. Martenzitické korozivzdorné oceli.	Structural steels with carbon content < 0,5 %, medium hard steels for treatment. Cast structural steels. Common tool steels, also harder steels for treatment. Martensitic stainless steels.
	P_{IV} 900÷1200 [N/mm ²]	Nástrojové oceli. Litě oceli s velkou pevností. Martenzitické korozivzdorné oceli.	Tool steels. Cast steels with high strength. Martensitic stainless steels.
M	-	Austenitické a feriticko-austenitické oceli korozivzdorné, žárovzdorné a žárupevné. Oceli nemagnetické a otěruvzdorné.	Austenitic and ferritic-austenitic, stainless steels, creep- resistant and heat-resistant steels. Nonmagnetic and abrasion resistant steels.
K	-	Šedé litiny nelegované i legované (42 24 ..). Tvárné litiny (42 23 ..). Temperované litiny (42 25 ..).	Grey cast irons alloyed and no alloyed. Nodular cast irons. Malleable cast irons.
N	-	Neželezné kovy, slitiny Al a Cu.	Non-ferrous metals, Al and Cu alloys.
S	-	Speciální žárupevné slitiny na bázi Ni, Co, Fe a Ti.	Special heat-resistant alloys on the basis of Ni, Co, Fe and Ti.
H	-	Zušlechťené oceli s pevností nad 1500 MPa. Kalené oceli HRC 45 ÷ 60. Tvrzené kokilové litiny HSh 55 ÷ 85.	Treated steels with strength over 1500 MPa. Hardened steels, HRC 45 ÷ 60. Tempered ingot mould irons, HSh 55 ÷ 85.

**DOPORUČENÉ PRŮMĚRY VRTÁKŮ POD ZÁVÍTY
RECOMMENDED TAP DRILL SIZES**

Metrické závit Metric ISO threads		Doporučený průměr vrtáku pro Recommended drill diameter for	
Závit Thread	Stoupání Pitch	řezací závitník thread milling	tvářecí závitník former tap

M4	0,70	3,3	3,7
M4 × 0,5	0,50	3,5	3,8
M4,5	0,75	3,7	4,2
M5	0,80	4,2	4,6
M5 × 0,5	0,50	4,5	4,8
M6	1,00	5,0	5,5
M6 × 0,75	0,75	5,2	5,7
M6 × 0,5	0,50	5,5	5,8
M7	1,00	6,0	6,5
M7 × 0,75	0,75	6,2	-
M8	1,25	6,8	7,4
M8 × 1,0	1,00	7,0	7,6
M8 × 0,75	0,75	7,3	7,7
M8 × 0,5	0,50	7,5	-
M9	1,25	7,8	-
M9 × 1,0	1,00	8,0	-
M10	1,50	8,5	9,3
M10 × 1,25	1,25	8,8	9,4
M10 × 1,0	1,00	9,0	9,6
M10 × 0,75	0,75	9,3	9,7
M10 × 0,5	0,50	9,5	-
M11	1,50	9,5	-
M12	1,75	10,2	11,2
M12 × 1,5	1,50	10,5	11,3
M12 × 1,25	1,25	10,8	11,4
M12 × 1,0	1,00	11,0	11,5
M12 × 0,75	0,75	11,3	-
M13 × 1,0	1,00	12,0	-
M14	2,00	12,0	13,0
M14 × 1,5	1,50	12,5	13,3
M14 × 1,25	1,25	12,8	-
M14 × 1,0	1,00	13,0	13,5
M14 × 0,75	0,75	13,3	-
M15 × 1,5	1,50	13,5	-
M15 × 1,0	1,00	14,0	-
M16	2,00	14,0	15,0
M16 × 1,5	1,50	14,5	15,3
M16 × 1,25	1,25	14,8	-
M16 × 1,0	1,00	15,0	15,5
M16 × 0,75	0,75	15,3	-
M17 × 1,0	1,00	16,0	-
M18	2,50	15,5	16,8
M18 × 2,0	2,00	16,0	-
M18 × 1,5	1,50	16,5	17,3
M18 × 1,0	1,00	17,0	-
M20	2,50	17,5	18,8
M20 × 2,0	2,00	18,0	-
M20 × 1,5	1,50	18,5	19,3
M20 × 1,0	1,00	19,0	-

Metrické závit Metric ISO threads		Doporučený průměr vrtáku pro Recommended drill diameter for	
Závit Thread	Stoupání Pitch	řezací závitník thread milling	tvářecí závitník former tap

M22	2,50	19,5	20,8
M22 × 2,0	2,00	20,0	-
M22 × 1,5	1,50	20,5	21,3
M22 × 1,0	1,00	21,0	-
M24	3,00	21,0	22,5
M24 × 2,0	2,00	22,0	-
M24 × 1,5	1,50	22,5	23,3
M27	3,00	24,0	-
M27 × 2,0	2,00	25,0	-
M30	3,50	26,5	-
M30 × 2,0	2,00	28,0	-
M33	3,50	29,5	-
M36	4,00	32,0	-
M36 × 3,0	3,00	33,0	-
M39	4,00	35,0	-
M42	4,50	37,5	-
M42 × 3,0	3,00	39,0	-
M45	4,50	40,5	-
M48	5,00	43,0	-
M48 × 3,0	3,00	45,0	-
M52	5,00	47,0	-
M52 × 3,0	3,00	48,0	-

DOPORUČENÉ PRŮMĚRY VRTÁKŮ POD ZÁVITY
RECOMMENDED TAP DRILL SIZES

Palcové závitы UNC Inch threads UNC		Doporučený průměr vrtáku pro Recommended drill diameter for	
Závit Thread	Stoupání Pitch	řezací závitník thread milling	tvářecí závitník former tap

No. 8	32	3,5	3,8
No. 10	24	3,9	4,3
No. 12	24	4,5	5,0
1/4	20	5,2	5,8
5/16	18	6,6	7,3
3/8	16	8,0	8,8
7/16	14	9,4	10,2
1/2	13	10,7	11,7
9/16	12	12,3	13,2
5/8	11	13,5	14,7
3/4	10	16,7	17,8
7/8	9	19,5	20,8
1	8	22,2	23,8
1 1/8	7	25,0	-
1 1/4	7	28,2	-
1 3/8	6	31,0	-
1 1/2	6	34,0	-
1 3/4	5	39,5	-
2	4 1/2	45,2	-
2 1/4	4 1/2	51,6	-
2 1/2	4	57,2	-

Palcové závitы UNF Inch threads UNF		Doporučený průměr vrtáku pro Recommended drill diameter for	
Závit Thread	Stoupání Pitch	řezací závitník thread milling	tvářecí závitník former tap

No. 8	36	3,5	3,9
No. 10	32	4,1	4,5
No. 12	28	4,6	5,1
1/4	28	5,5	5,9
5/16	24	6,9	7,5
3/8	24	8,5	9,0
7/16	20	9,9	10,5
1/2	20	11,5	12,1
9/16	18	13,0	13,6
5/8	18	14,5	15,2
3/4	16	17,5	18,3
7/8	14	20,5	21,3
1	12	23,4	24,3
1 1/8	12	26,5	-
1 1/4	12	29,8	-
1 3/8	12	33,0	-
1 1/2	12	36,0	-

Whitworthovy závitы Whitworth pipe threads		Doporučený průměr vrtáku pro Recommended drill diameter for	
Závit Thread	Stoupání Pitch	řezací závitník thread milling	tvářecí závitník former tap

G 1/16	28	6,8	7,3
G 1/8	28	8,8	9,3
G 1/4	19	11,8	12,5
G 3/8	19	15,3	16,0
G 1/2	14	19,0	20,0
G 5/8	14	21,0	22,0
G 3/4	14	24,5	25,5
G 7/8	14	28,3	29,3
G 1	11	30,8	32,0
G 1 1/8	11	35,5	-
G 1 1/4	11	39,5	-
G 1 3/8	11	41,8	-
G 1 1/2	11	45,3	-
G 1 3/4	11	51,0	-
G 2	11	57,0	-

MEZ PEVNOSTI STRENGTH [MPa]	Tvrdost / Hardness			
	BRINELL	VICKERS	ROCKWELL	ROCKWELL
Rm	HB	HV	HRB	HRC
285	86	90	1190	—
320	95	100	56,2	—
350	105	110	62,3	—
385	114	120	66,7	—
415	124	130	71,2	—
450	133	140	75	—
480	143	150	78,7	—
510	152	160	81,7	—
545	162	170	85,8	—
575	171	180	87,1	—
610	181	190	89,5	—
640	190	200	91,5	—
675	199	210	93,5	—
705	209	220	95	—
740	219	230	96,7	—
770	228	240	98,1	—
800	238	250	99,5	—
820	242	255	—	23,1
850	252	265	—	24,8
880	261	275	—	26,4
900	266	280	—	27,1
930	276	290	—	28,5
950	280	295	—	29,2
995	295	310	—	31
1030	304	320	—	32,2
1060	314	330	—	33,3
1095	323	340	—	34,4
1125	333	350	—	35,5
1155	342	360	—	36,6

MEZ PEVNOSTI STRENGTH [MPa]	Tvrdost / Hardness			
	BRINELL	VICKERS	ROCKWELL	ROCKWELL
Rm	HB	HV	HRB	HRC
1190	352	370	—	37,7
1220	361	380	—	38,8
1255	371	390	—	39,8
1290	380	400	—	40,8
1320	390	410	—	41,8
1350	399	420	—	42,7
1385	409	430	—	43,6
1420	418	440	—	44,5
1455	428	450	—	45,3
1485	437	460	—	46,1
1520	447	470	—	46,9
1555	456	480	—	47,7
1595	466	490	—	48,4
1630	475	500	—	49,1
1665	485	510	—	49,8
1700	494	520	—	50,5
1740	504	530	—	51,1
1775	513	540	—	51,7
1810	523	550	—	52,3
1845	532	560	—	53
1880	542	570	—	53,6
1920	551	580	—	54,1
1955	561	590	—	54,7
1995	570	600	—	55,2
2030	580	610	—	55,7
2070	589	620	—	56,3
2105	599	630	—	56,8
2145	608	640	—	57,3
2180	618	650	—	57,8

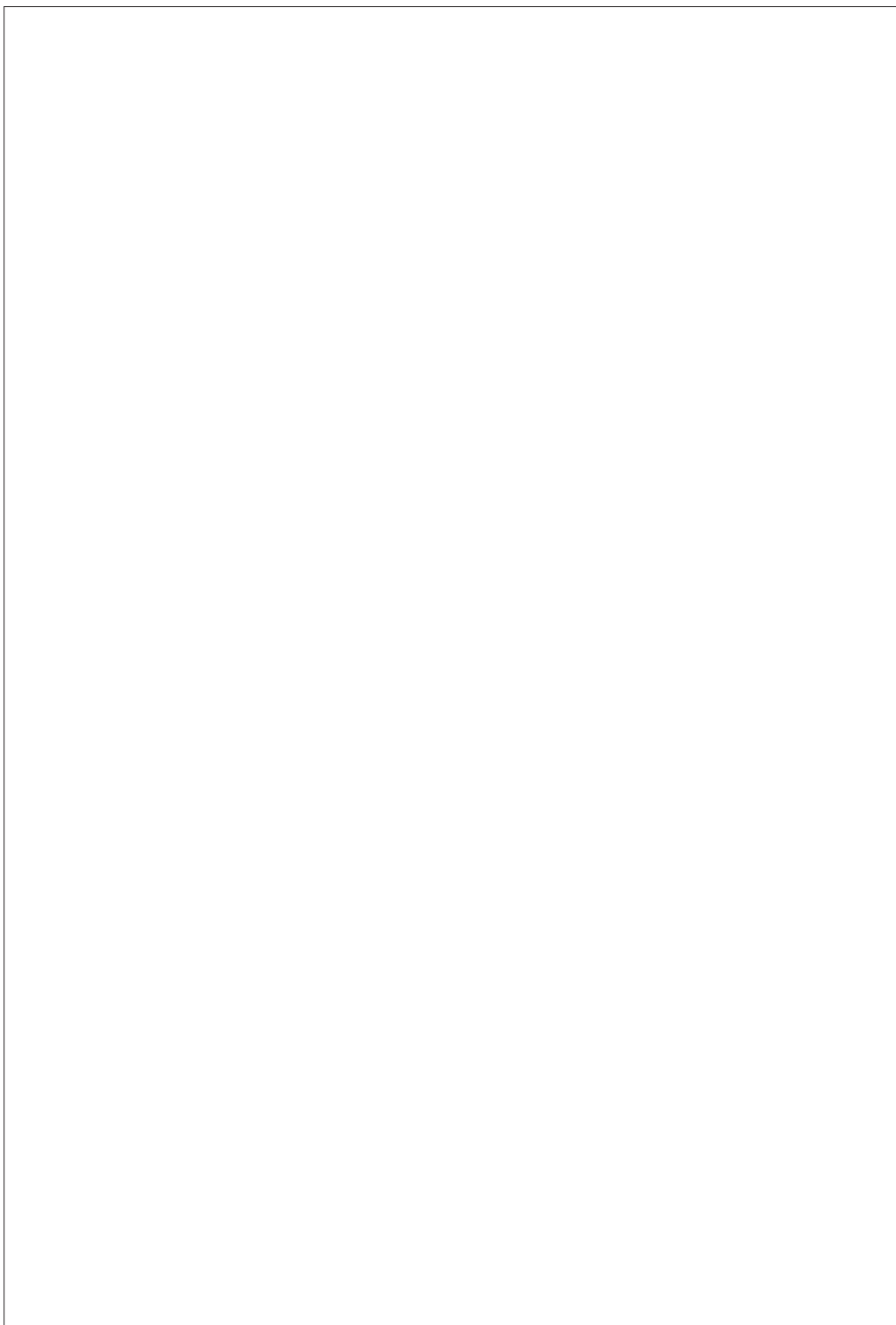

OBSAH
CONTENT

MONOLITNÍ VRTÁKY
SOLID DRILLS

DESTÍČKOVÉ VRTÁKY
INDEXABLE DRILLS

VYMĚNITELNÉ DESTÍČKY
INDEXABLE INSERTS

NASTAVITELNÉ POUZDRO
ADJUSTABLE SLEEVE

ŘEZNÉ PODMÍNKY
CUTTING CONDITIONS

TECHNICKÁ ČÁST
TECHNICAL PART

OBSAH
CONTENT

MONOLITNÍ VRTÁKY
SOLID DRILLS

DESTIČKOVÉ VRTÁKY
INDEXABLE DRILLS

VYMĚNITELNÉ DESTIČKY
INDEXABLE INSERTS

NASTAVITELNÉ POUZDRO
ADJUSTABLE SLEEVE

ŘEZNÉ PODMÍNKY
CUTTING CONDITIONS

TECHNICKÁ ČÁST
TECHNICAL PART



Pramet Tools, s.r.o., Uničovská 2, CZ-787 53 Šumperk, CZECH REPUBLIC

Phone: +420 583 381 111, Fax: + 420 583 215 401, E-mail: pramet.info.cz@pramet.com

BRAZIL • Pramet Ind. e Com. de Ferramentas Ltda., Sorocaba/SP, Tel./Fax: +55 15 3325-6162, E-mail: pramet.info.br@pramet.com

GERMANY • Pramet GmbH, Erlangen, Telefon: + 49 9131 / 93 37 40, E-mail: pramet.info.de@pramet.com

CHINA • Pramet Tools (Shanghai) Co., Ltd., Shanghai, Phone: +86 138 0171 3812, E-mail: pramet.info.cn@pramet.com

HUNGARY • Pramet Kft., Budapest, Tel.: + 36-1-382-90-82, E-mail: pramet.info.hu@pramet.com

INDIA • Pramet Tools India Pvt Ltd, Gurgaon, Phone: + 91 124 4703825, E-mail: pramet.info.in@pramet.com

ITALY • Pramet SRL, Lainate (MI), Telefono: + 39 02 / 93 79 94 82, E-mail: pramet.info.it@pramet.com

POLAND • Pramet Sp. z o.o., Sosnowiec, Telefon: + 48 32 / 78 15 890, E-mail: pramet.info.pl@pramet.com

RUSSIA • ООО «Прамет», Москва, РФ, Тел.: +7 495 739 57 23, 739 57 22, E-mail: pramet.info.ru@pramet.com

SLOVAKIA • Pramet Slovakia, Žilina, Telefon: + 421 41 / 764 54 60, E-mail: pramet.info.sk@pramet.com

www.pramet.com